

CV-4

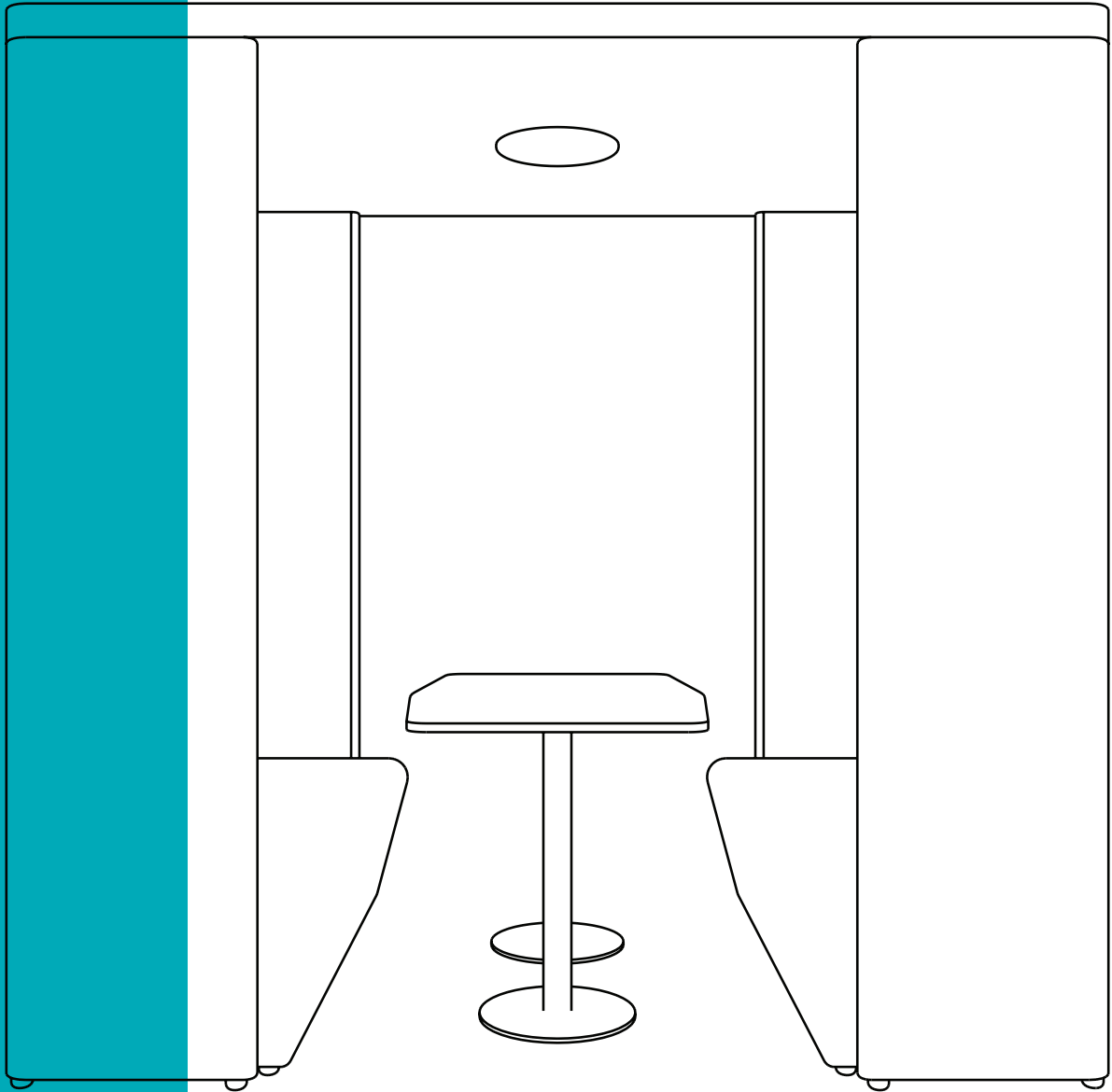

**CLEAR**  
DESIGN

## COVE 4-PERSON OPEN-PANEL MEETING POD

\*General Guide | See Master Plan

Instructions in English and en Español



## 1 | MEASURE TO APPROXIMATE WIDTH

Measure **85"** from the outer edge of the pod or **78.7"** from the inner wall of the pod to find the approximate width. Once positioned, roof panel may be installed.

Alinee los levantadores para que estén al ras con los agujeros de unión en el panel adyacente.  
Empuje contra las paredes exteriores de el booth hasta que los paneles estén al ras.

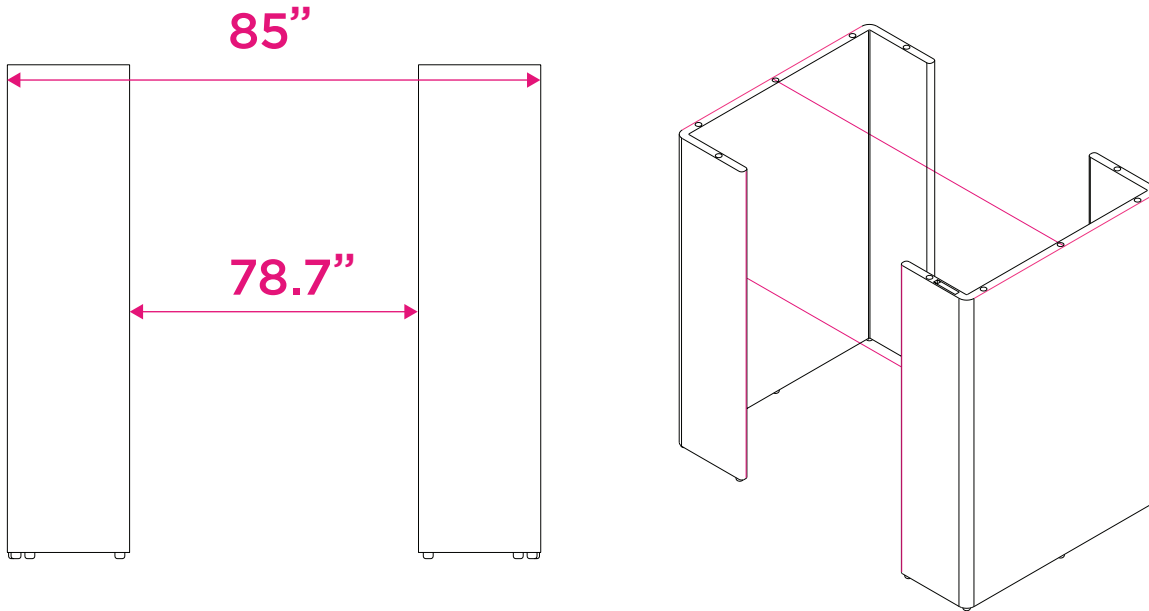

## 2 | SECURE CONNECTING STEEL DOWELS TO TOP PANEL

Insert connecting steel dowel plate into the marking hole on the bottom side of the top panel and insert four  $\frac{3}{4}$ " screws through the flat plate to secure. Repeat step for all 10 lifters.

Inserte el extremo del soporte plano del levantador en el agujero marcado en el lado inferior del panel superior e inserte cuatro tornillos de  $\frac{3}{4}$ " a través de la placa plana para asegurar. Repita este paso para los 10 levantadores.

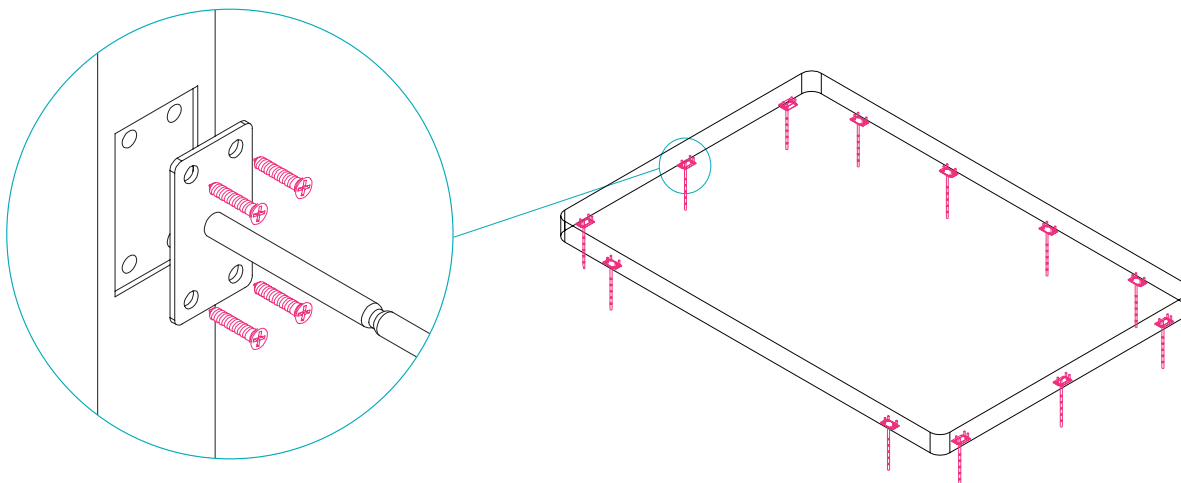

### 3 | CONNECT MAIN POWER

Assemble the connector joint by securing the male and female halves together and securing with connector clips to the top and bottom of the assembly.

Ensamble la unión del conector asegurando las mitades masculinas y femeninas juntas y asegúrelas con los clips conectadores en la parte superior e inferior del conjunto.

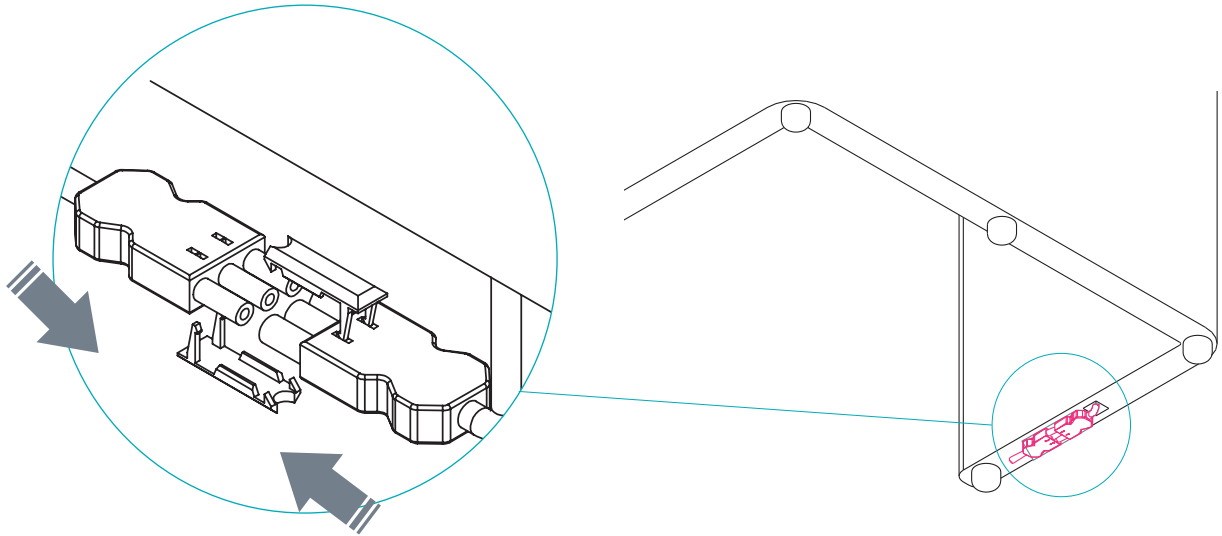

### 4 | CONNECT POWER TO TOP PANEL

Assemble the connector joint by securing the male and female halves together and securing with connector clips to the top and bottom of the assembly. Once connected, tuck completed assembly into slot at the top of the side panel.

Ensamble la unión del conector asegurando las mitades masculinas y femeninas juntas y asegurándolas con los clips conectadores en la parte superior e inferior del conjunto. Una vez conectado, inserte el ensamblaje completo en la ranura en la parte superior del panel lateral.

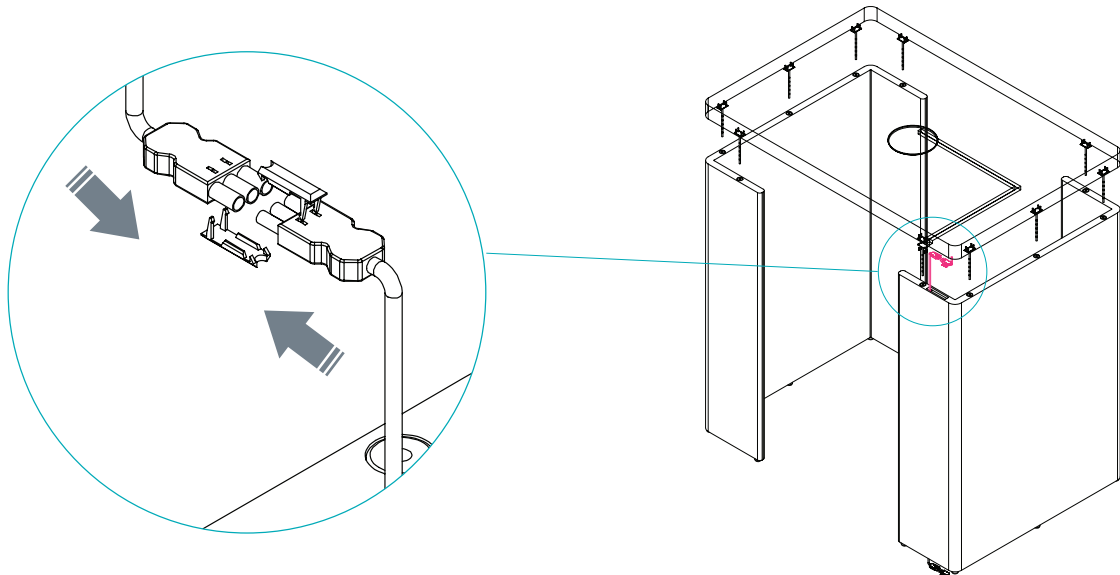

## 5 | SECURE TOP PANEL

Line up steel dowels so they are flush with the joint holes on the adjacent panel.  
Push against the outer walls of the booth until panels are flush.

Alinee los levantadores para que estén al ras con los agujeros de unión en el panel adyacente.  
Empuje contra las paredes exteriores de el booth hasta que los paneles estén al ras.

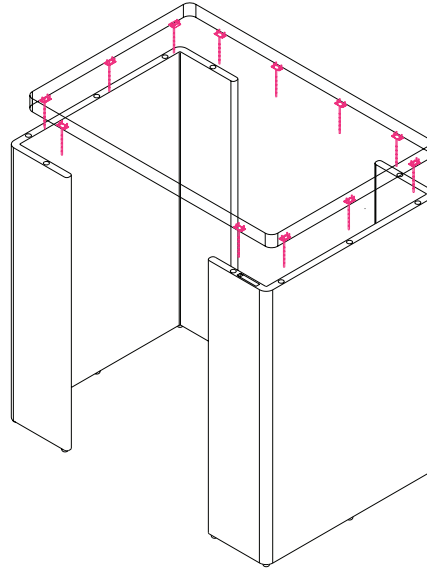
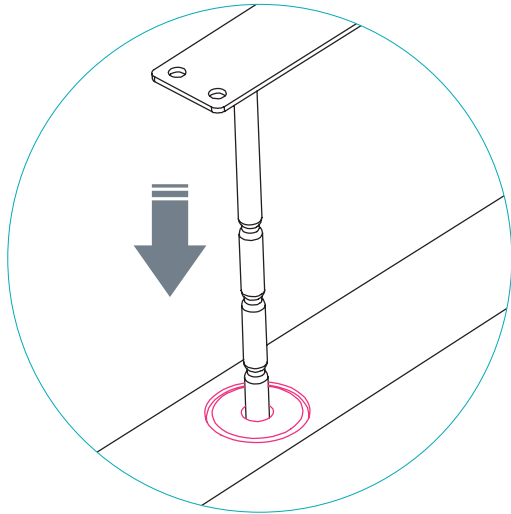

## 6 | SECURE LEGS TO TABLE

Insert 4 screws through the pre-drilled holes of each table base into the bottom surface of the table.

Inserte 4 tornillos a través de los agujeros pre-taladrados de la base de la mesa en la superficie inferior de la mesa.

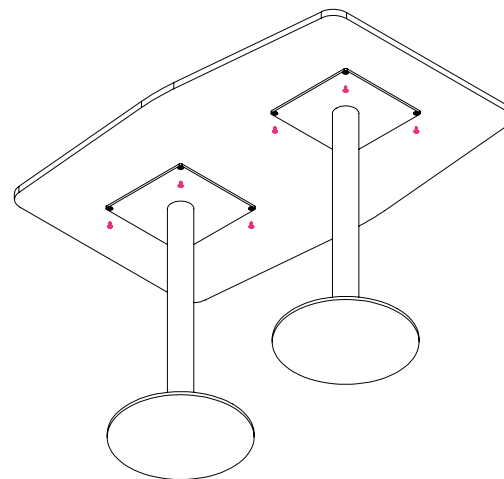
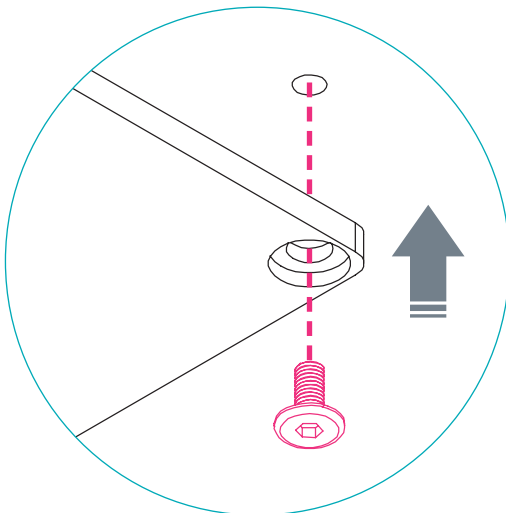

## 7 | PLACE SEATS INSIDE BOOTH

Tilt seat at a 45 degree angle. Slide into the COVE booth while tilting the seat back so that the seat sits flat on the floor.

Incline el asiento en un ángulo de 45 grados. Deslíze el asiento dentro del booth COVE mientras inclinas el respaldo para que el asiento quede plano en el piso.

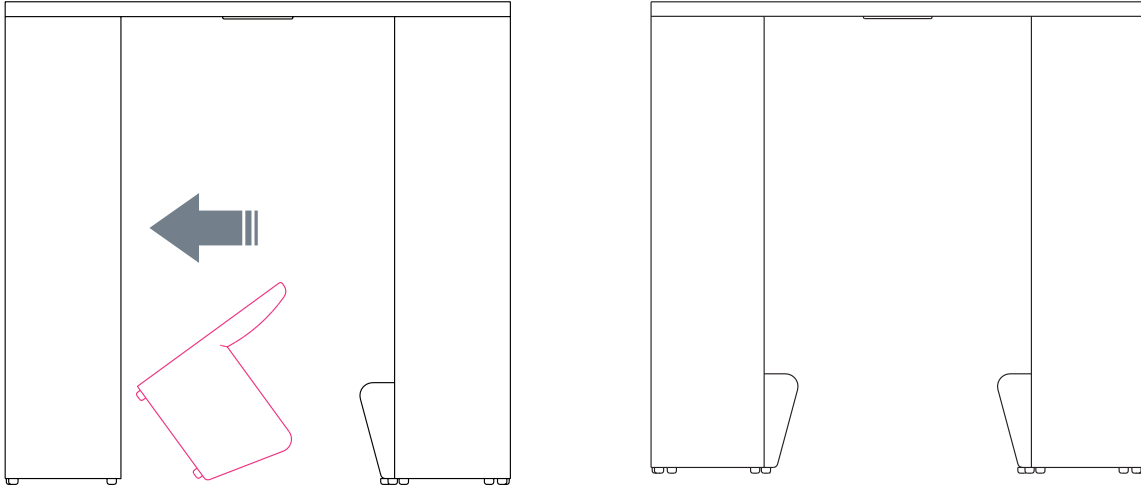

## 8 | FINISHING TOUCHES

Place table inside booth.

Coloque el asiento y la mesa dentro de la cabina.

