



---

# Components & Optional Accessories

## Components

---

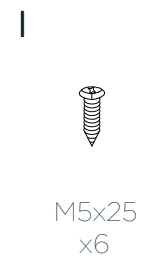
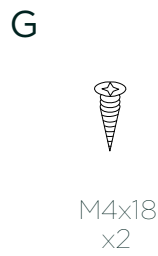
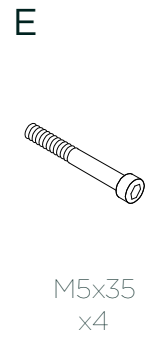
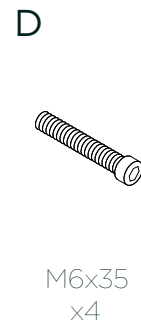
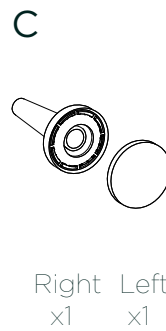
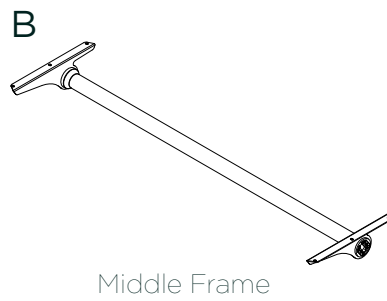
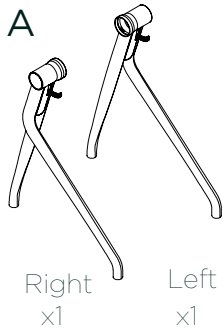

---

## Optional (Modesty Panel)

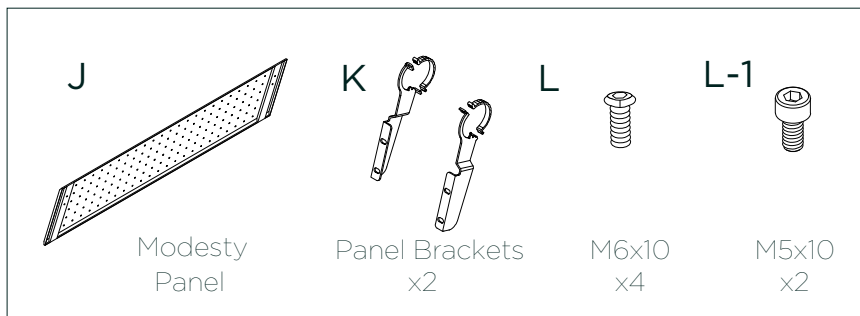

---

## Optional (Ganging De-

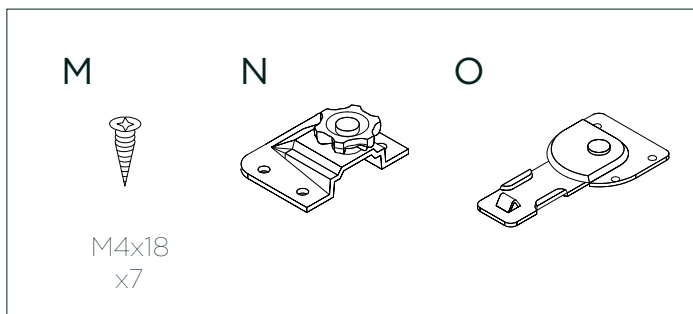

# Phase 1 | Concur Assembly

## Step 1

Select one leg (A) and attach it to the middle frame (B) with one of the D screws. Tighten a bit but not completely.

Insert a second D screw and loosely tighten. Now tighten both (D) screws completely.

Next, tighten the (E) screws in the same method you used for the (D) screws, leaving loose until all 4 are in place and then tightening.

Repeat with the other leg.

## Step 2

Twist to insert the (C) push button bracket, followed by the button cover. Repeat on the other side.

## Step 3

Turn the worksurface upside down and center align the Worksurface Support (F). Now turn the leg and middle frame assembly upside down.

Adjust the Middle Frame (B) and the Worksurface Support (F), please make sure that the worksurface center line is aligned with the lower edge of the second hole of the cantilevers during installation. Please mark the screw holes position.

Attach the Worksurface Support (F) to the worksurface using the (G) screws (x2).

Attach the worksurface to the cantilevers of the frame assembly using the (I) screws (x6).

Insert the castors firmly into the legs until locked in place.

## Step 4

Turn your finished CONCUR table over to use.

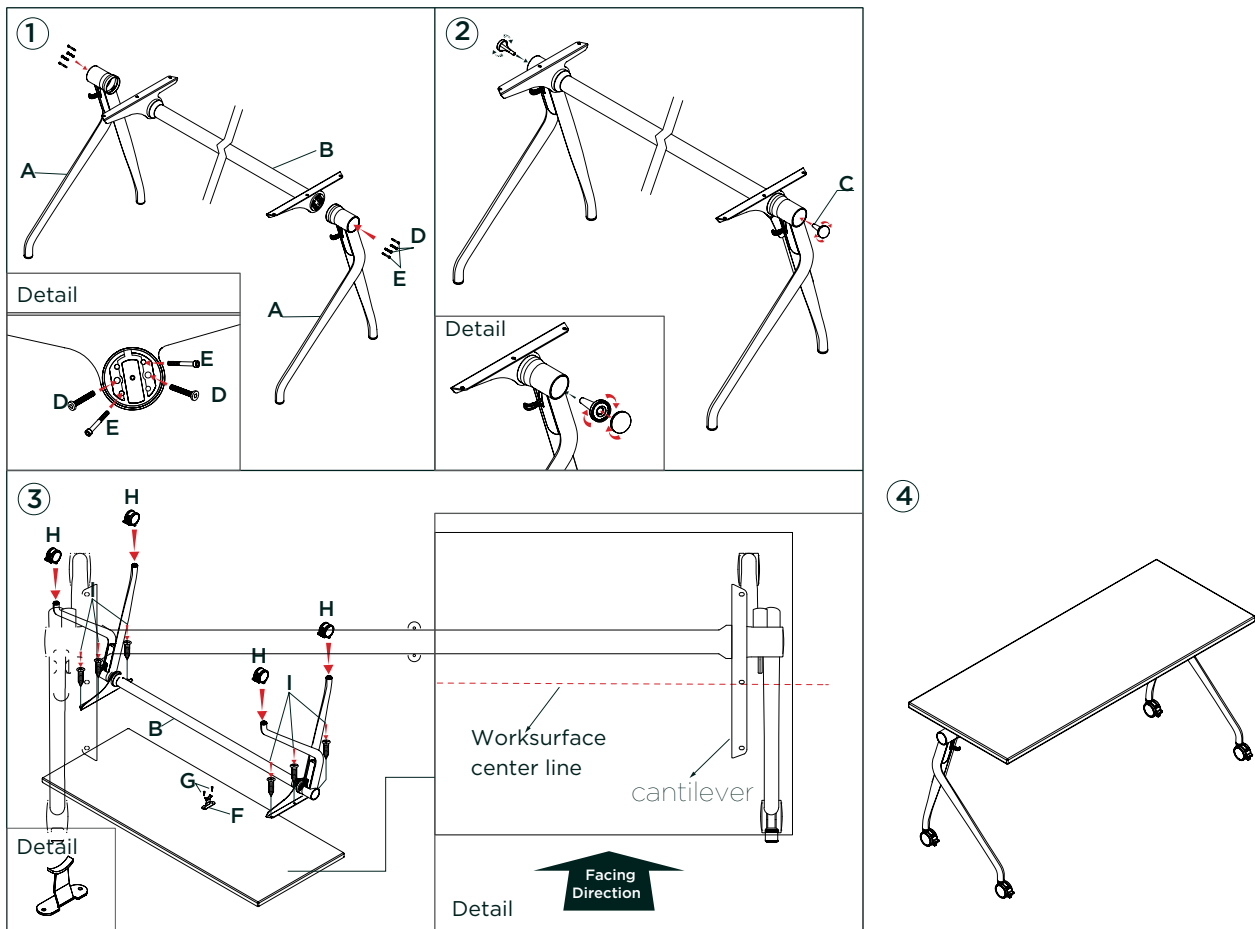

## Phase 2 | Attaching Modesty Panel (Optional)

### Step 1

Connect the Panel Brackets (K) to the middle frame (B), locking it with the (L-1) screws (x2).

### Step 2

Connect the Modesty Panel (J) and panel brackets with the (L) screws (x4).

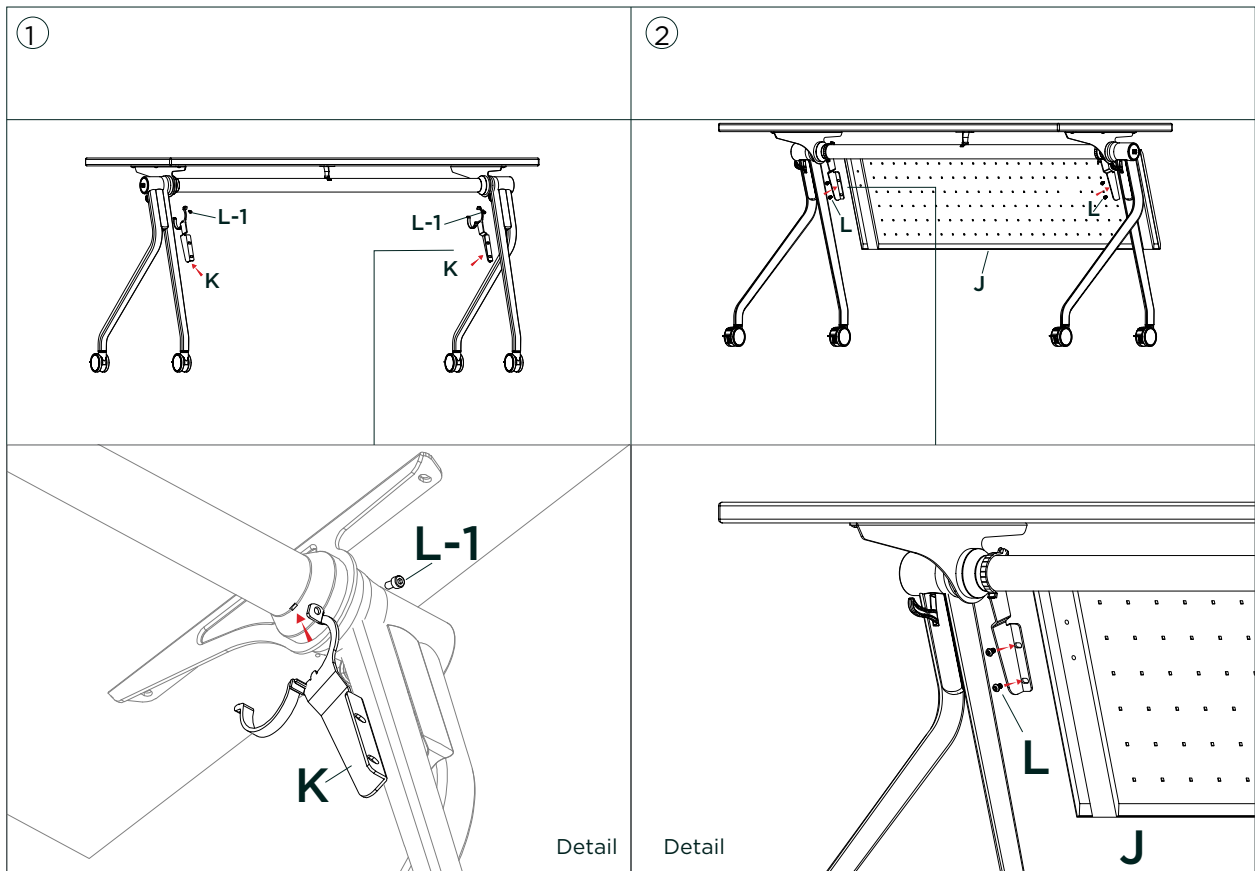
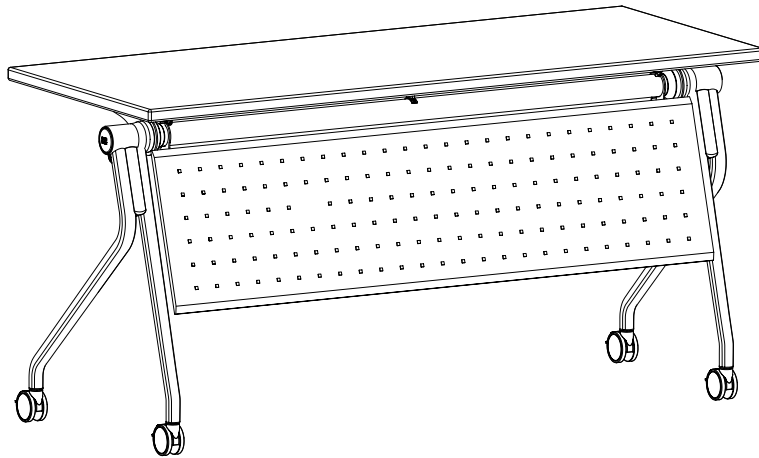

# Phase 3 | Attaching Ganging Device (Optional)

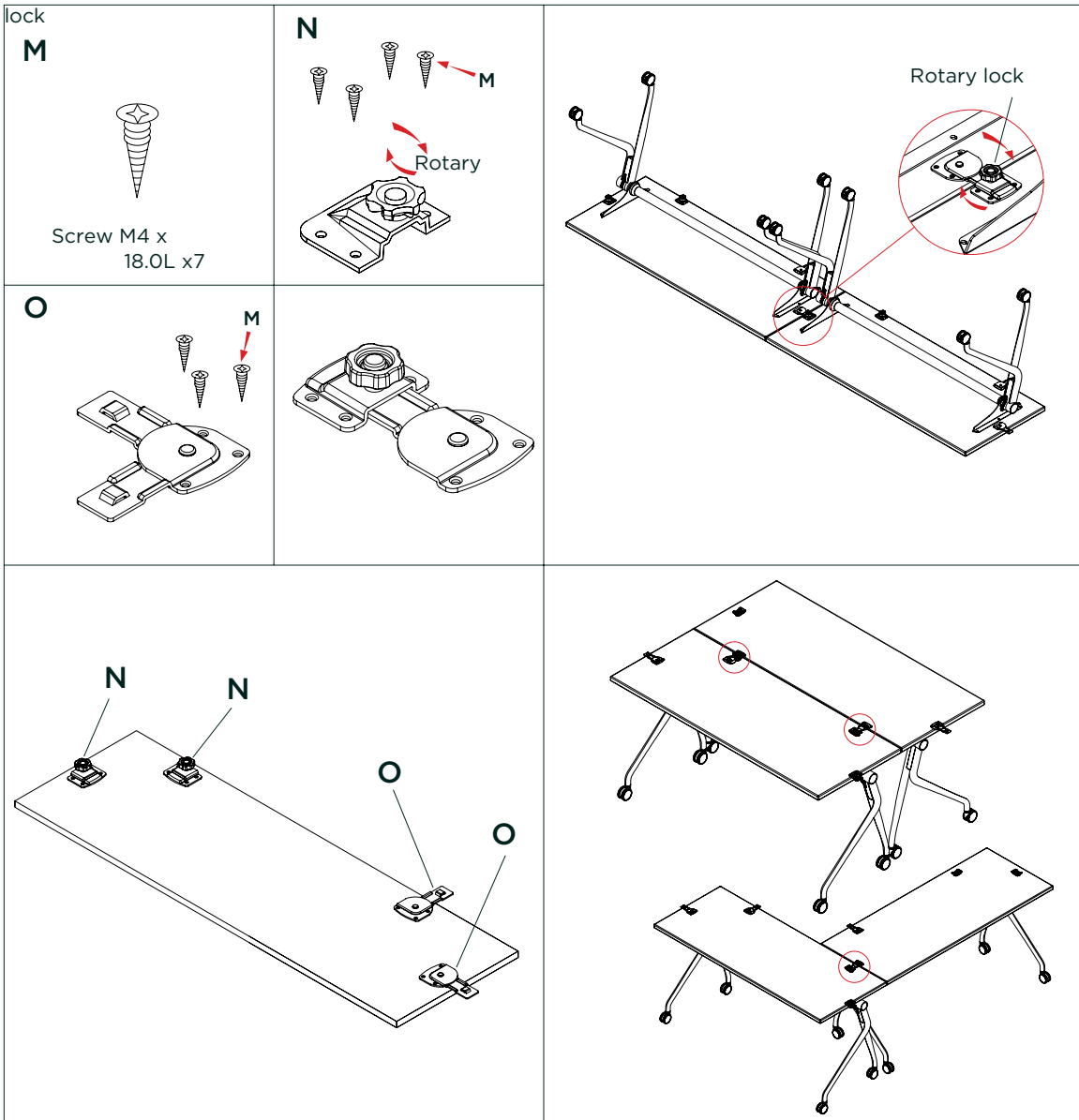
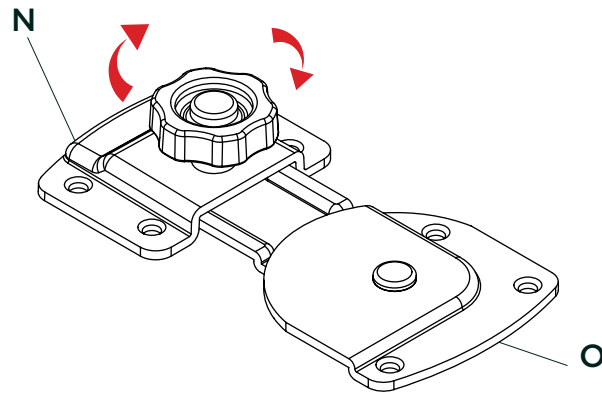

Please contact [inspire@mycleardesign.com](mailto:inspire@mycleardesign.com)  
if you are missing any parts, have  
difficulty with assembly, or have any  
product related questions.