

CLEAR
DESIGN

Helix™
Height Adjustable Benching



Benching, Elevated.

Helix™ reimagines height-adjustable benching through a combination of **fast installation, flexible configurations, and distinctive design**. Together with Tonos™ privacy screens, Helix™ creates a workplace solution that feels smarter and more elevated — designed to support performance, comfort and rapid deployment.



A Revolution in Speed.

WELCOME HELIX™

Helix™ is our **proprietary, patent-pending** height-adjustable benching system engineered for superior design, reconfigurability and speed of assembly.

Helix™ transforms one of the industry's biggest pain points: installation. While traditional benching systems can take 1-2 hours to assemble, Helix™ frames **install in just 10 minutes** per workstation—no tools required. With a lightweight beam construction, shared joints, and locking cantilevers, Helix™ brings a new level of innovation and ease to our height adjustable workstation portfolio.

Helix™ frames in Silver | Carbon Tonos™ PET screens | Shadow Elm Laminate | Apex Work Chair with Fern seat
Silver STOHR Box/File Pedestals with Fern cushions

TOOL-FREE FRAME ASSEMBLY

While traditional benching systems can take 1-2 hours to install, Helix™ frames are designed for **tool-free assembly in just 10 minutes**—enabling a faster, simpler, and more streamlined experience from delivery to day one.

HELIX™ OUT OF THE BOX —
BEAM SHIPS FOLDED

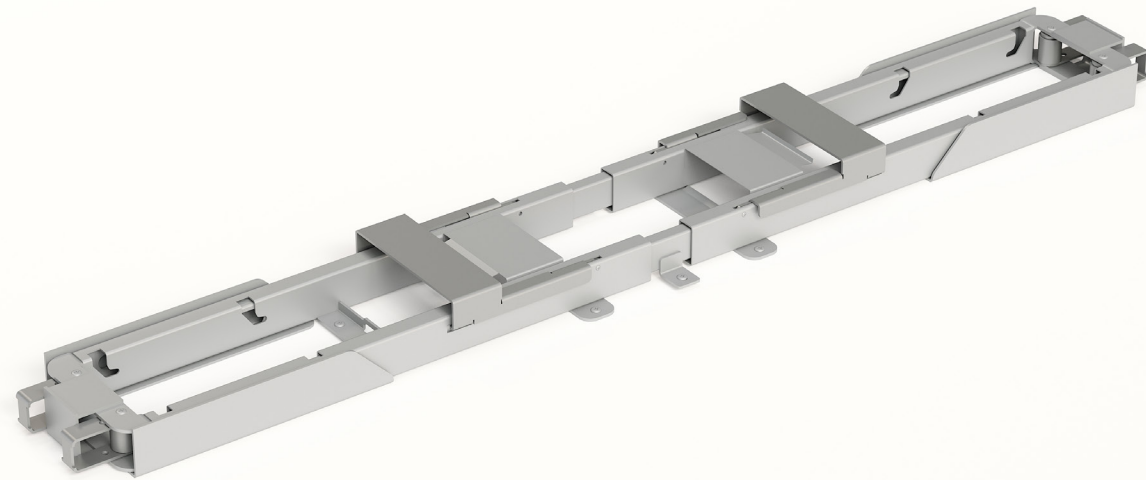

SIMPLY INSERT THE LEG AND EXTEND
THE CANTILEVERS TO LOCK INTO PLACE

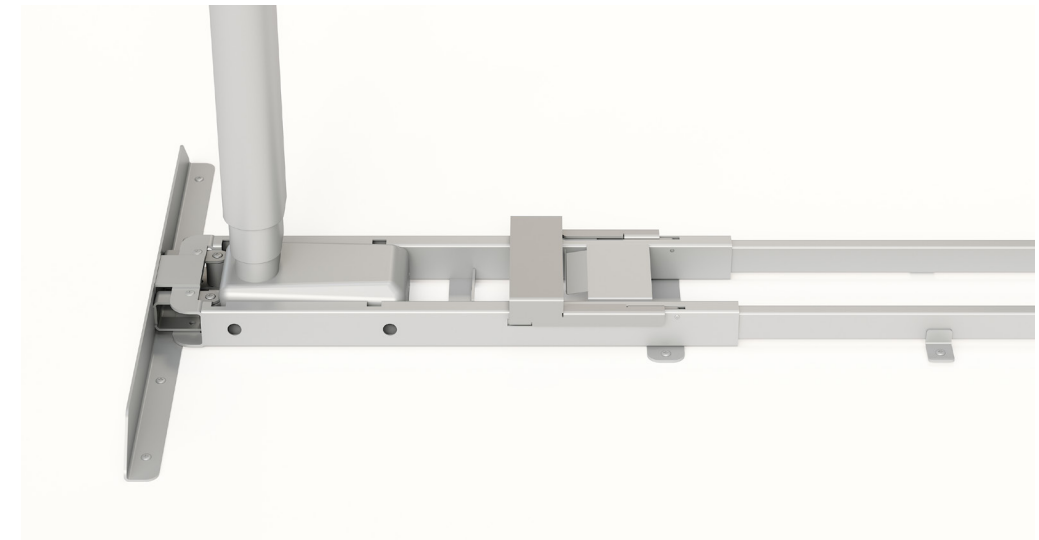

**Proprietary,
patent-pending
assembly.**

In a category long defined by complexity and a labor-intensive setup, Helix™ introduces a revolutionary approach — engineered for tool-free frame assembly, ready to go straight out of the box.



Linear and 90° configurations,
single and double runs



Privacy options include PET, fabric
or glass screens



Digital handset controller with
4 memory presets



Helix™ Frames in Silver with Harbor Sleeves | Electric White Laminate | Tonos® Screens in Harbor
 Silver STOHR File-File Mobile Pedestals with Harbor Cushions | White Apex Work chairs with Harbor Seats

HELIX™

Height Adjustable Benching



3 PILLARS OF HELIX™

01 — FAST

Helix™ dramatically simplifies the installation process through a lightweight beam structure, shared joints, and intuitive, tool-free frame assembly —reducing setup from hours to just minutes.

02 — FRESH

With an updated visual signature that includes oval columns and distinctive slip-on leg sleeves, Helix™ introduces a more elevated and innovative aesthetic for height-adjustable benching.

03 — FLEXIBLE

Designed for modern workplace layouts, Helix™ supports single and double runs, 90-degree applications, adjustable widths, integrated cable management, and adaptable accessories for evolving team needs.

Helix™ integrates seamlessly with our Tonos™ privacy screens, for an entirely integrated open plan solution. With Helix™, even the most agile and evolving workplaces are supported in their open plan needs.



“Installation has historically been one of the biggest friction points in benching. With Helix™, we’ve re-engineered the process — simplifying the build without compromising structural integrity, functionality, or design.”

— SABBY PAPNOI, CLEAR DESIGN PRODUCT ENGINEER



Helix™ Features

- Tool-free frame assembly—engineered for fast and easy installation
- Height-adjustable 3-stage, oval legs
- Single run, double run, and 90-degree options
- Adjustable widths from 48”-84”
- Lightweight beam structure with shared joint design and cantilever lock
- Integrated cable management and dedicated power beam
- Signature slip-on Leg Sleeves in multiple colorways add a distinctive, design-forward look
- ANSI-BIFMA X10.1-2024



Helix™ integrates seamlessly with our Tonos™ PET privacy screens, shown here in Linen. Add Fern Leg Sleeves for an inviting, contemporary aesthetic.



DESIGNED FOR EASE AND FLEXIBILITY

Helix™ in Black Steel | White Oak Laminate | Tonos™ Screens in Alloy
 Black STOHR File-File Pedestals with Fern Cushion tops
 Black Apex Work chairs with Fern Seats

Feet stabilize
 Single Runs
 and Returns



Linear and 90° applications



Coordinated Gallery
 End Panels, storage and
 privacy screens create
 a total height adjustable
 workstation solution.

Tonos™ PET privacy screens
 can be mounted to beam
 or worksurface



Leg Sleeves in 4 colorways add
 a design-forward aesthetic



Helix™ combines height-adjustable performance with easy scalability to support evolving workplaces. With adjustable widths from 48"-84" and configurations including single runs, double runs, and 90-degree applications, Helix™ flexes easily across a wide range of environments.

Helix™ in Black Steel | White Oak Laminate | Apex Work Chair in Black with Ash Seats
STOHR mobile Box/File Pedestal with Ash Cushion | Tonos™ PET Privacy Screens in Ash

MATERIALS & FINISHES

Steel



Black



Silver



White

Laminate



Shadow Elm



White Oak

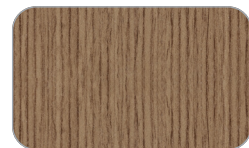

Sahara Ridge

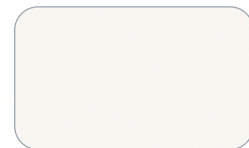

Electric White

FX PROGRAM: Additional laminate finishes are available on a 20-business-day lead time.

Aluminum



Canyon



Shale



Fern



Harbor

PET

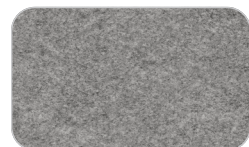

Luna

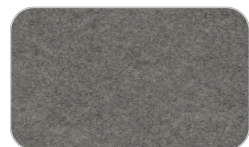

Alloy



Carbon

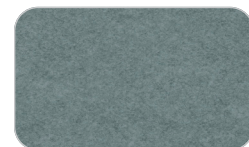

Harbor



Linen



Shale



Canyon

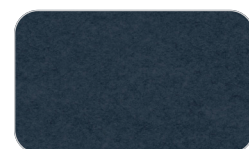

Twilight

*Available Winter 2026



Enhance the look of your Helix™ benching with aluminum Leg Sleeves in coordinating colorways.

CLEAR
DESIGN
Workspace made easy

