

# BOOST L-SHAPE

## HEIGHT-ADJUSTABLE WORKSTATION

Includes Add-Ons: **A1** | **A2** | **A3**

---

General Installation Guide



**EDITION CODE**

**BHALGSA** :: Workstation .....1

**ADD-ONS**

**A1** :: Modesty Panel ..... 7

**A2** :: Slim Pedestal ..... 11

**A3** :: Cable Tray ..... 15

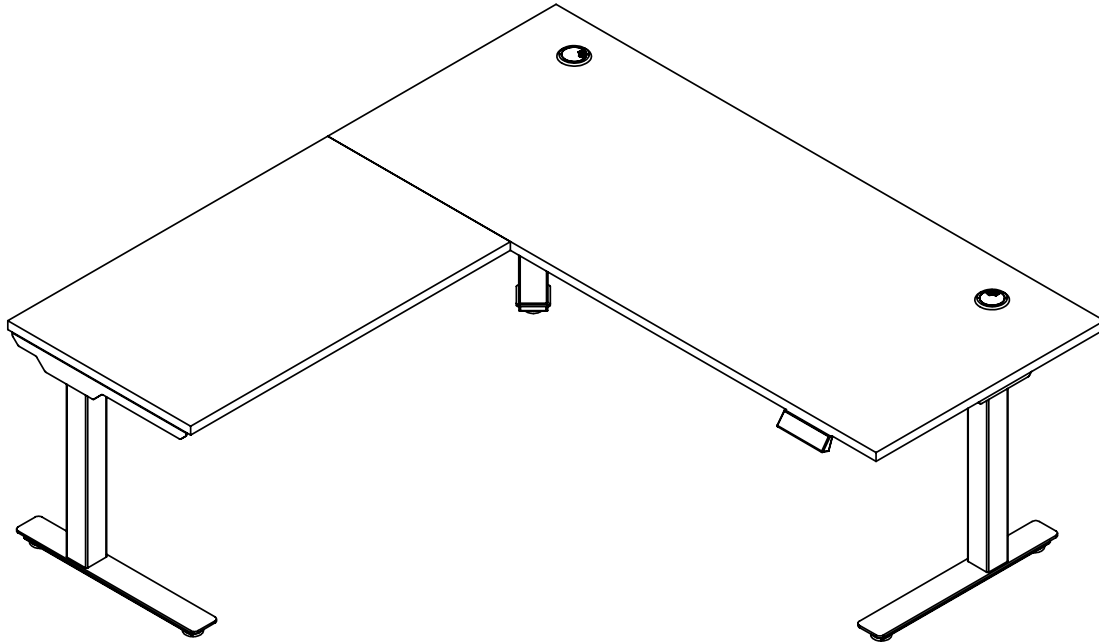



## WORKSTATION











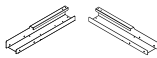



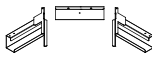



### OVERVIEW

BOOST L-Shape Height-Adjustable Workstation

**!** All parts listed are for a single workstation; additional parts will be needed for additional workstations.

### PARTS LIST ( ♻ Symbol indicates components is recyclable at end of use)

CODE	QTY	DESCRIPTION	
#####	2	Surface	
BASB72	2	Support Bar	
BFB1	2	Flat Bracket	

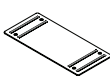
CODE	QTY	DESCRIPTION	
BHALGSA	1	Right & Left-Adjustable Beam $\Delta$	
	1	Inner-Adjustable Beam $\Delta$	
	1	Feet (Set of 2) $\Delta$	
	2	23" Arm Bracket $\Delta$	
	1	Center Post Brackets (L, REAR, & R)	
	1	Center Post Base	
	3	Leg with Motor $\Delta$	
	1	Handset	
	5	Glides	
	3	Extension Cords (SHRT, MED, & LG)	
	1	Power Cable	
	14	Screw (A)	
	8	Screw (B)	
	2	Screw (C)	
	8	Screw (D)	
	4	Screw (E)	
	39	Screw (F)	
	2	Screw (G)	
	1	Flat Plate	

## 1 | ASSEMBLE LEG POST SEPARATELY

Attach center leg with motor to the center post brackets using screws (A). Then, attach side legs with motor and arm brackets to left and right adjustable beams.

Note: Replace the default arm brackets if workstation requires BHA19 or T-brackets.

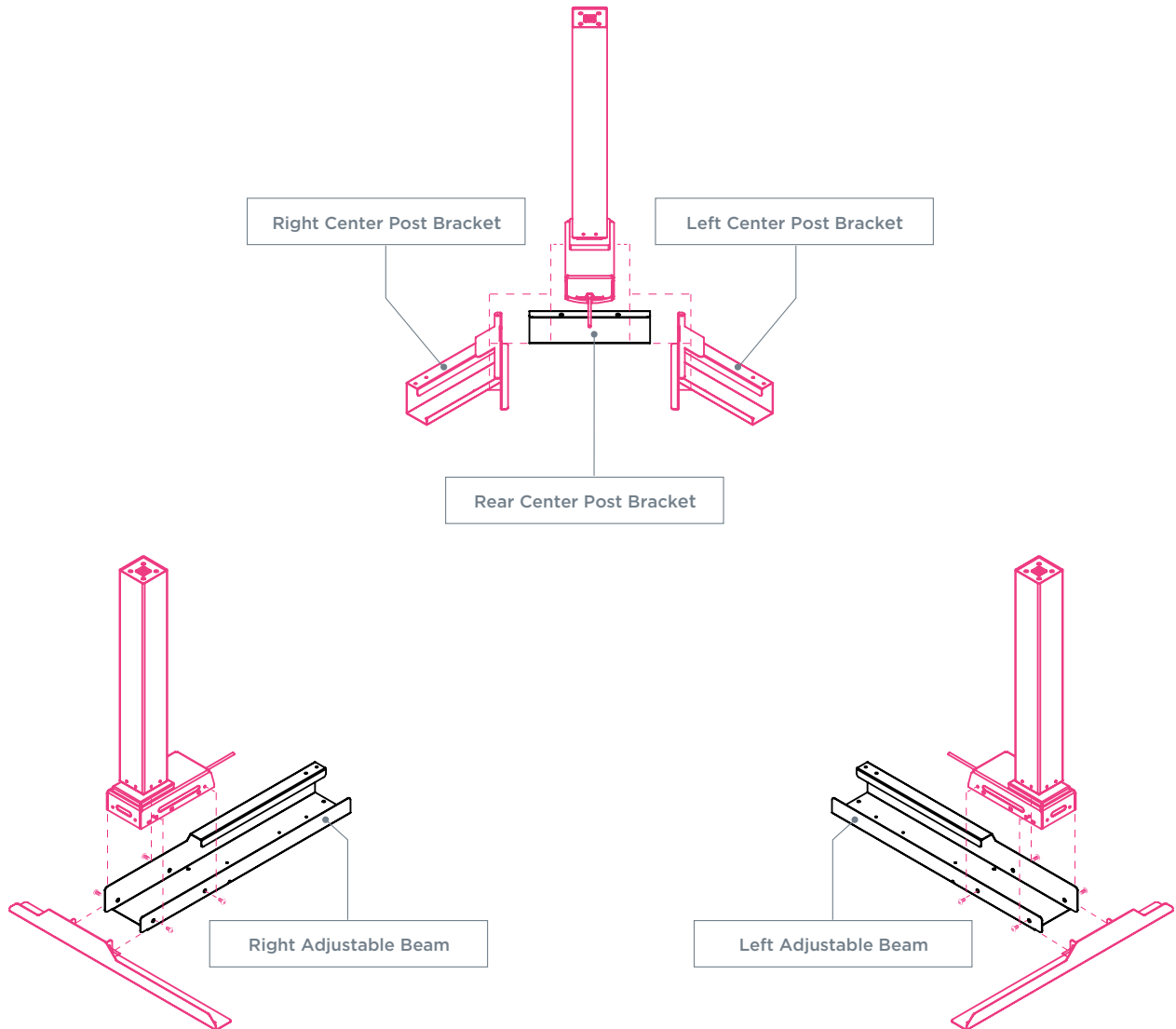

## 2 | ATTACH WORKSTATION FRAME

Join all three legs by attaching the inner adjustable beams to the left and right adjustable beams and center post brackets. Keep locking screws (B) loose on the inner adjustable beams to accommodate surface size in step 3.

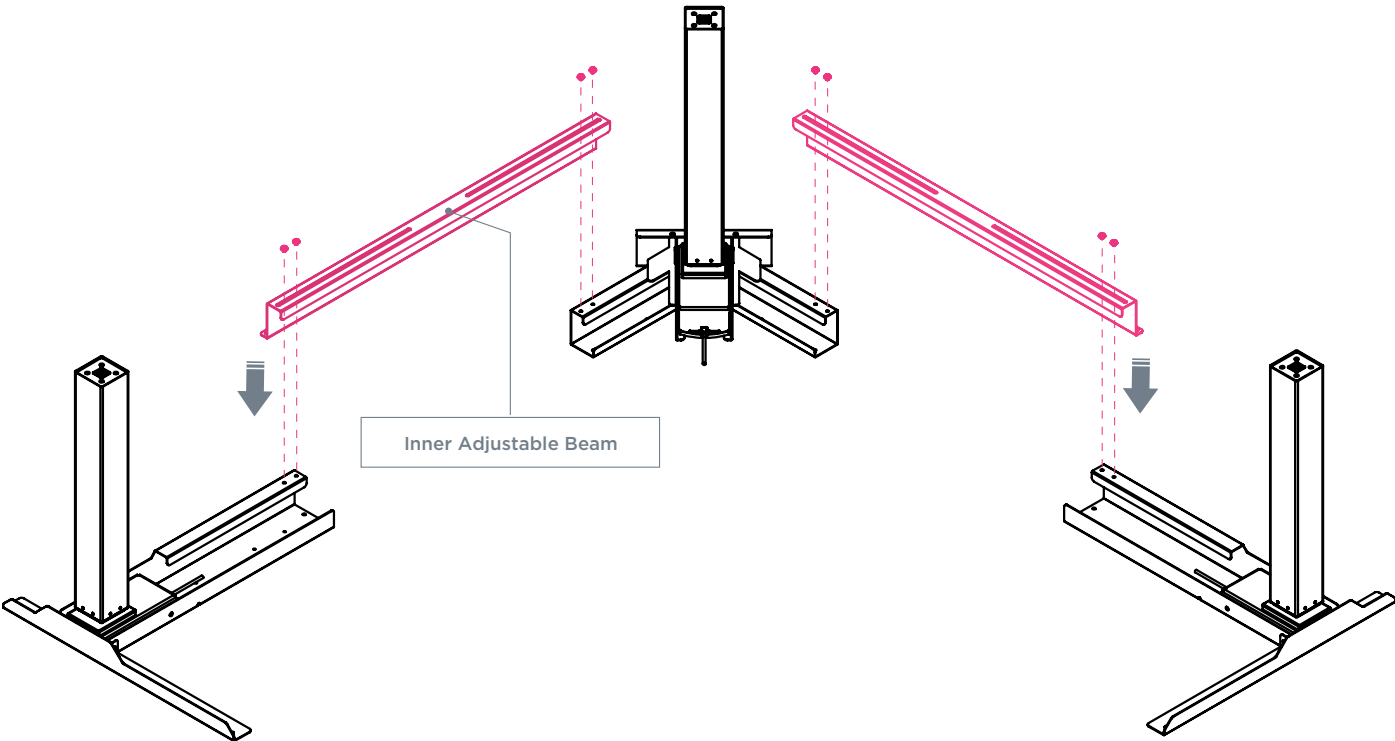

### 3 | PLACE FRAME ON SURFACE

Secure flat plate, flat bracket(s), and support bars to the surfaces using screws (F).

Extend beam to fit table size accordingly. Secure locking screws on the adjustable beam and attach to surface using screws (F).

**Note:** If using surface-mounted dividers, keep the frame 1.5 inches inset from the surface edge. If not using surface-mounted dividers, bring frame flushed to edge of surface. Use additional flat brackets as needed.

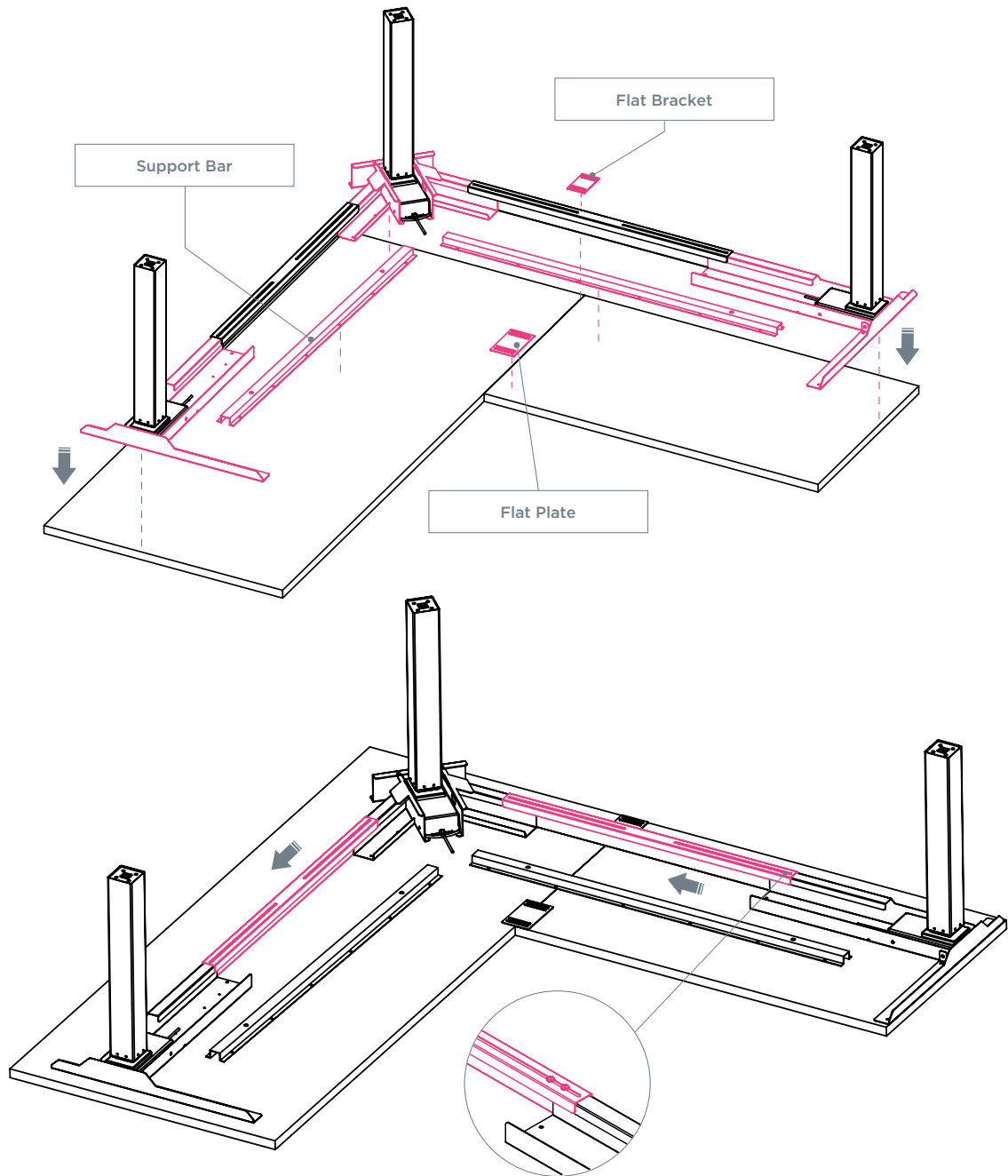

## 4 | INSTALL FEET, GLIDERS, AND CONTROL BOX , THEN SECURE POWER.

Install feet using screws (D) for outside legs. Install center post base to center leg using screws (E). Mount control box to the adjustable beam using screw (G). Then, secure power cord to the control box. Mount handset using wood screws (C) and attach to control box. If workstation is complete, flip over. Reference handset guide for initialization and operation functions.

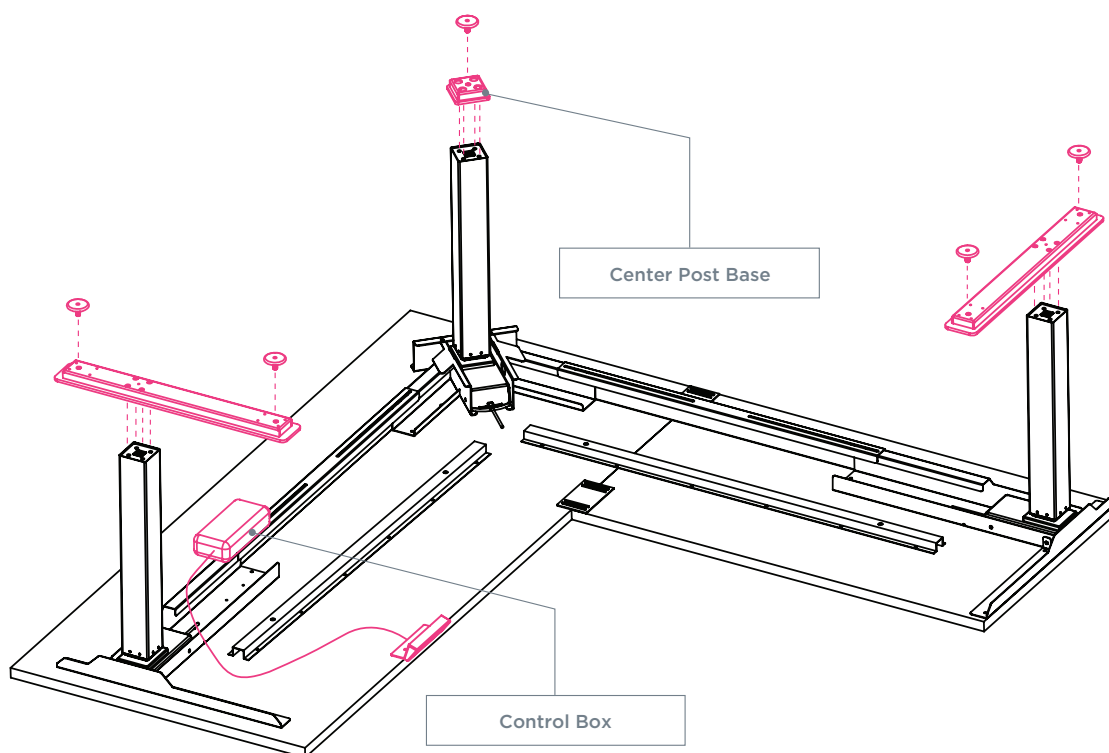

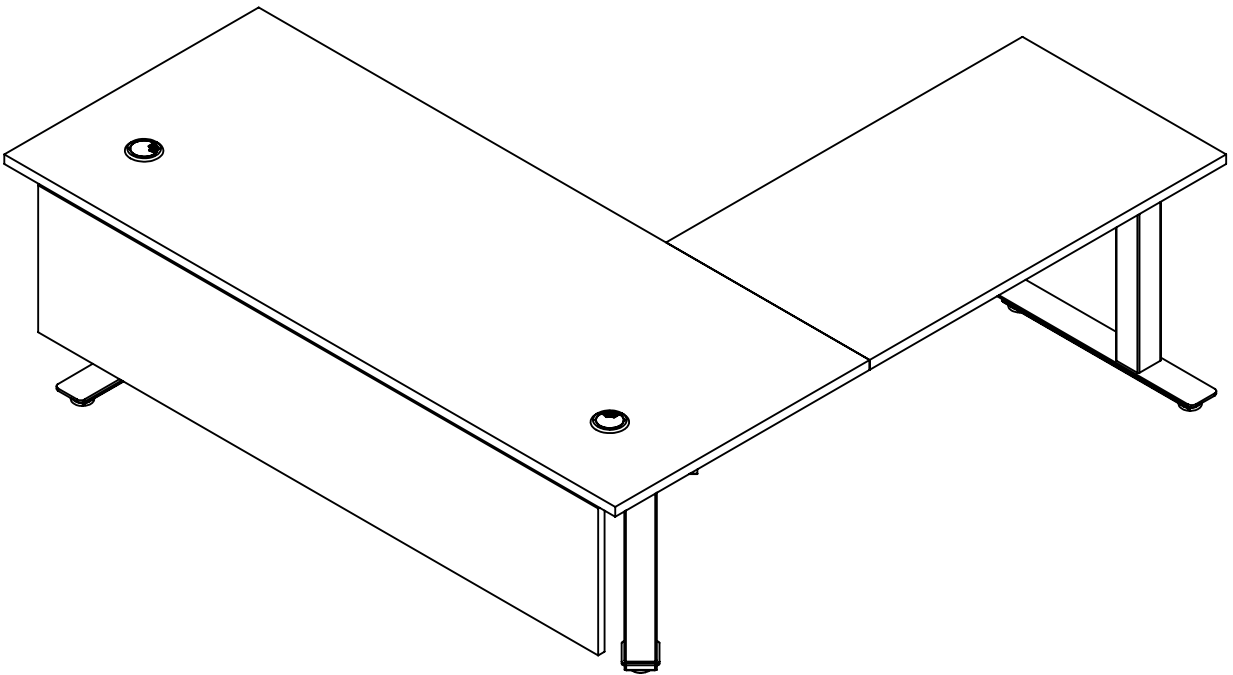

## A2: MODESTY PANEL





### OVERVIEW

---

BOOST L-Shape Height-Adjustable Workstation

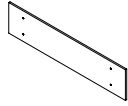
**!** All parts listed are for a single modesty panel; additional parts will be needed for additional modesty panels.

**PARTS LIST**

CODE	QTY	DESCRIPTION	
GLMP##	1	Laminate Modesty Panel*	
	4	Machine Screws	
BMPBFB	2	L-Brackets	
	4	Wood Screws*	

\*NOTE: For Steel Modesty Panel: components may vary, but process is similar.

## 1 | SECURE BRACKETS TO MODESTY PANEL

Connect the BMPBFB bracket to the modesty panel using screws.  
Secure tightly.

**NOTE:** If modesty panel does not have pre-drilled holes, use wood screws instead of machine screws.

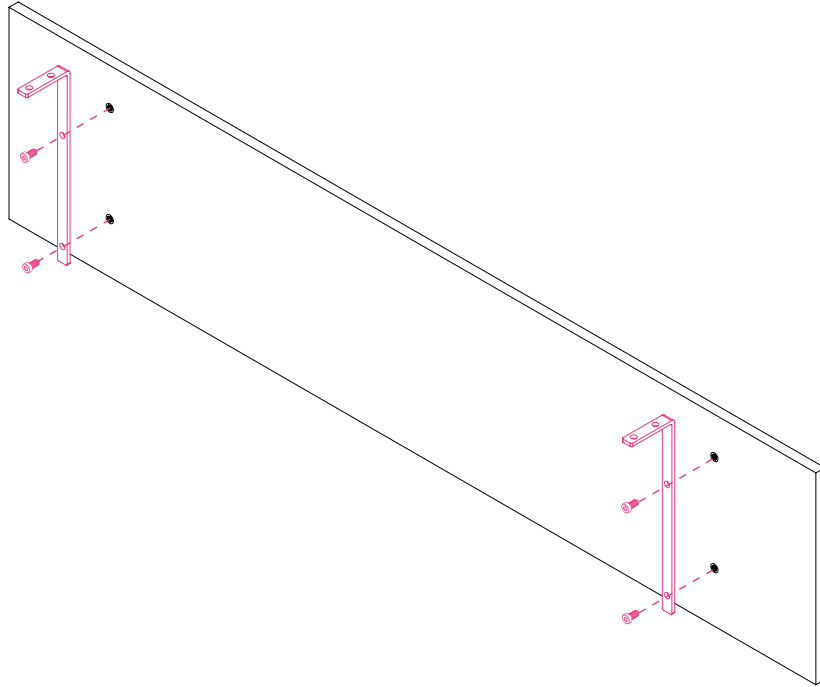

## 2 | ATTACH MODESTY PANEL TO SURFACE

Attach modesty panel to surface using wood screws provided with brackets. Panel will be center aligned and flushed with back of surface.

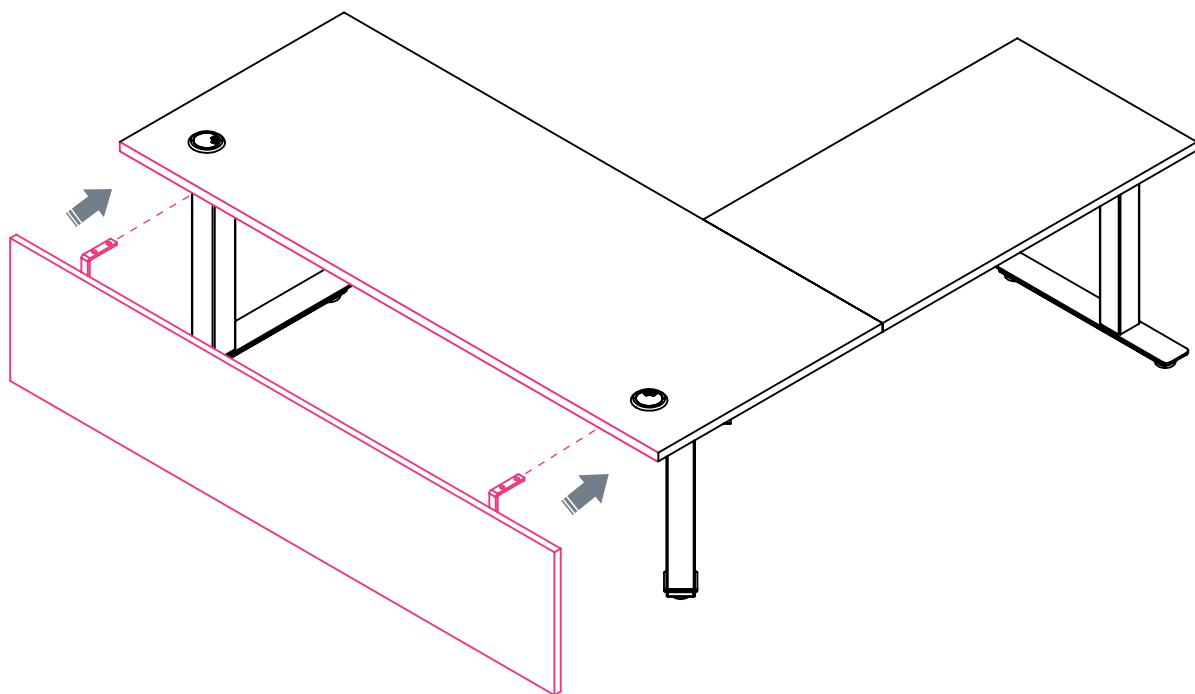

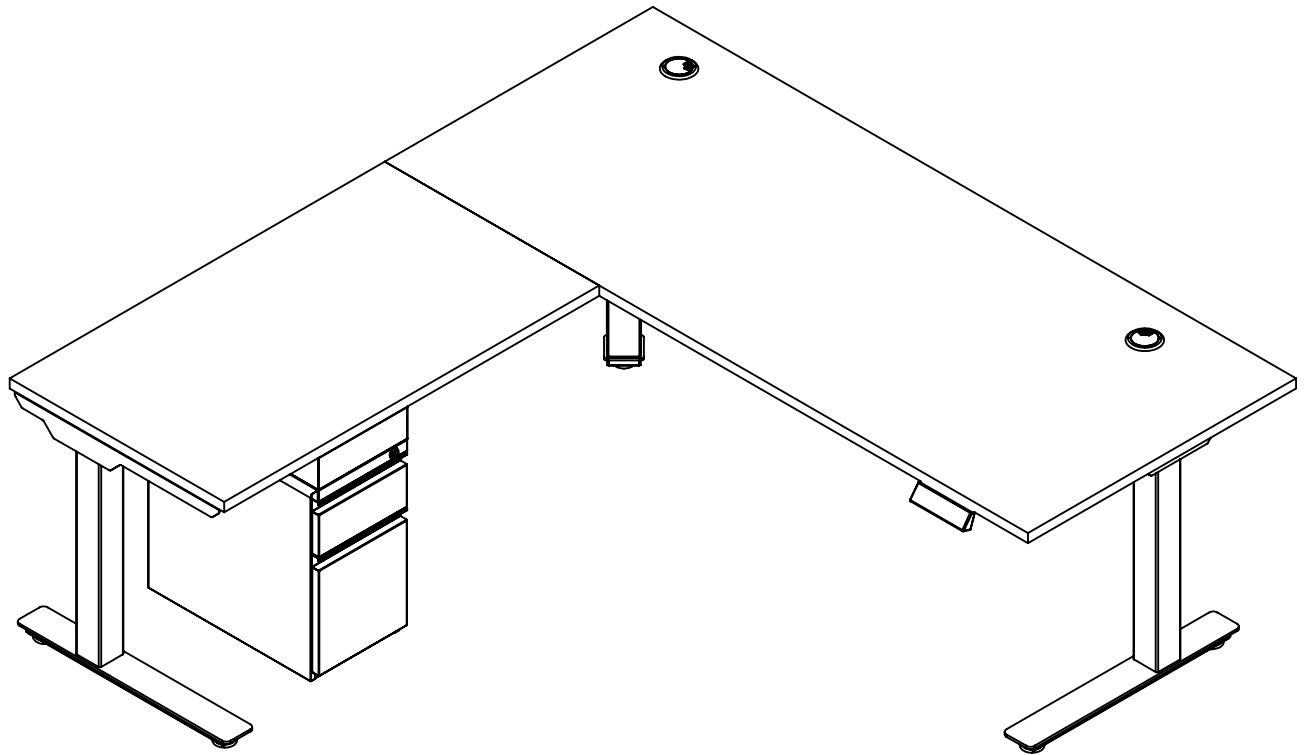

## A3: SLIM PEDESTAL

### OVERVIEW

---

BOOST L-Shape Height-Adjustable Workstation

**!** All parts listed are for a single slim pedestal; additional parts will be needed for additional slim pedestals.

## PARTS LIST

CODE	QTY	DESCRIPTION	
BFSLM.SM	1	Large Mounting Bracket	
	1	Small Mounting Bracket	
BFSLM	1	Slim Pedestal	
BFSLM.HW	8	Machine Screw	
	10	Wood Screw	

## 1 | SECURE BRACKETS TO SLIM PEDESTAL

Align large mounting bracket to front of pedestal and align small mounting bracket to back. Secure both brackets using provided screws.

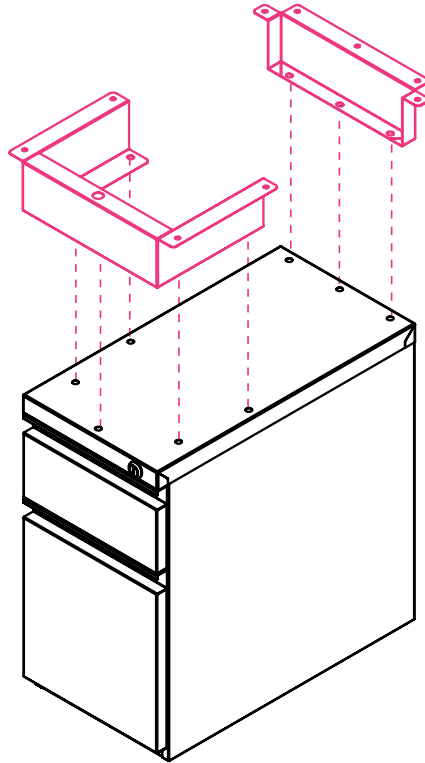

## 2 | ATTACH SLIM PEDESTAL TO SURFACE

Secure pedestal to surface using wood screws. The pedestal brackets will connect on either side of the center beam.

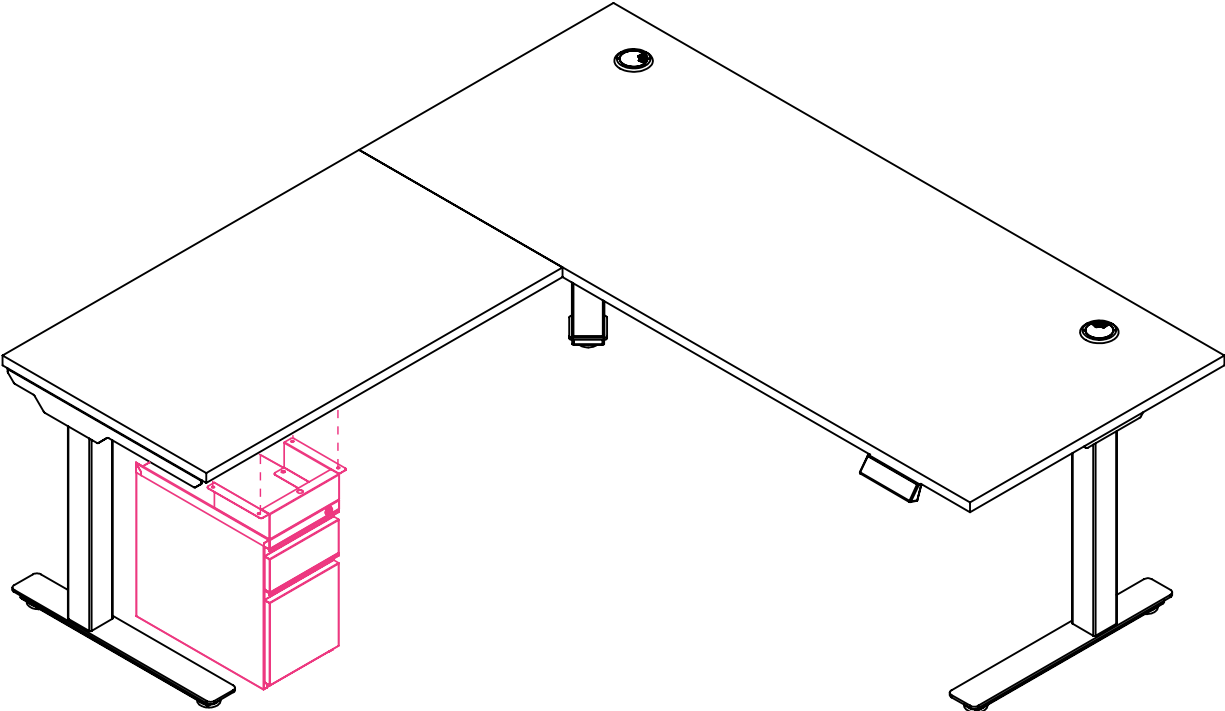

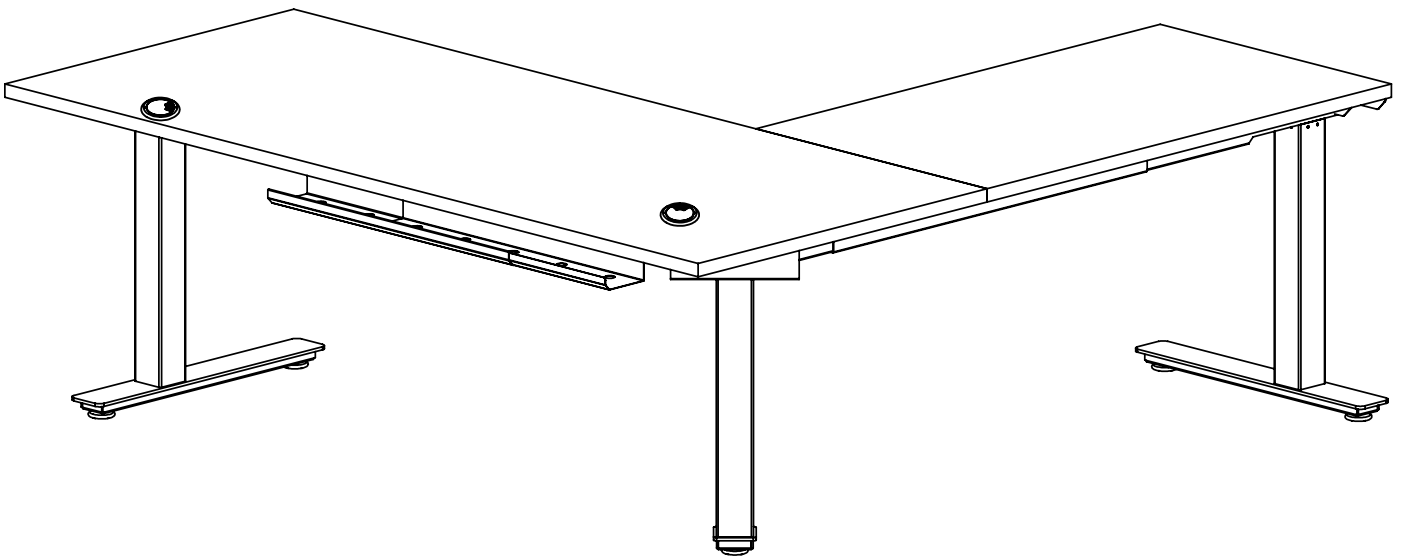

## A4: CABLE TRAY



### OVERVIEW

---

BOOST L-Shape Height-Adjustable Workstation

**!** All parts listed are for a single cable tray; additional parts will be needed for additional cable trays.

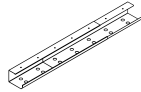
**PARTS LIST**

CODE	QTY	DESCRIPTION	
BHCT	1	Surface-Mount Cable Management Tray	
	10	Wood Screws	

## 1 | EXTEND CABLE TRAY TO DESIRED LENGTH

Extension range: 25"-45".

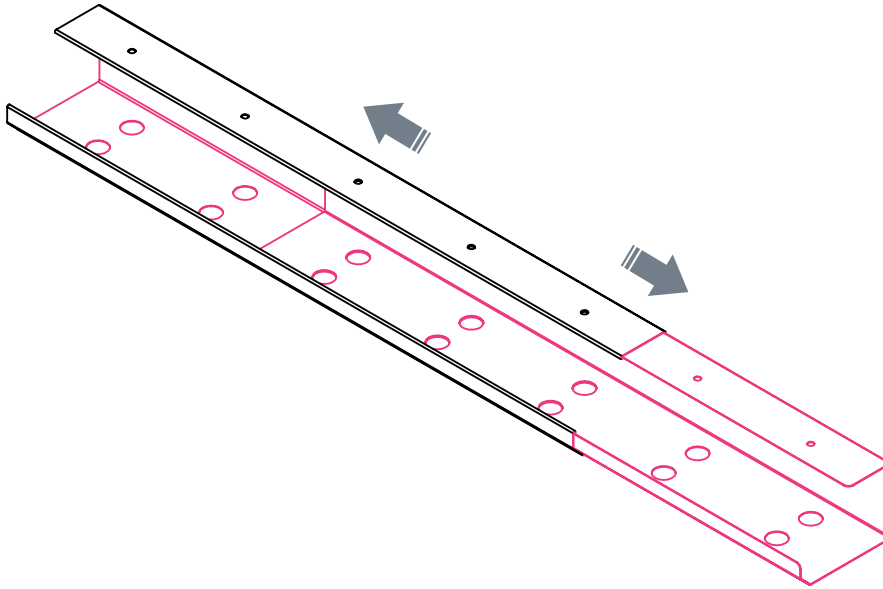

## 2 | ATTACH CABLE TRAY TO SURFACE

Attach cable tray using wood screws.

