

**CLEAR**  
DESIGN

BHA2GSA/BHA3GSA

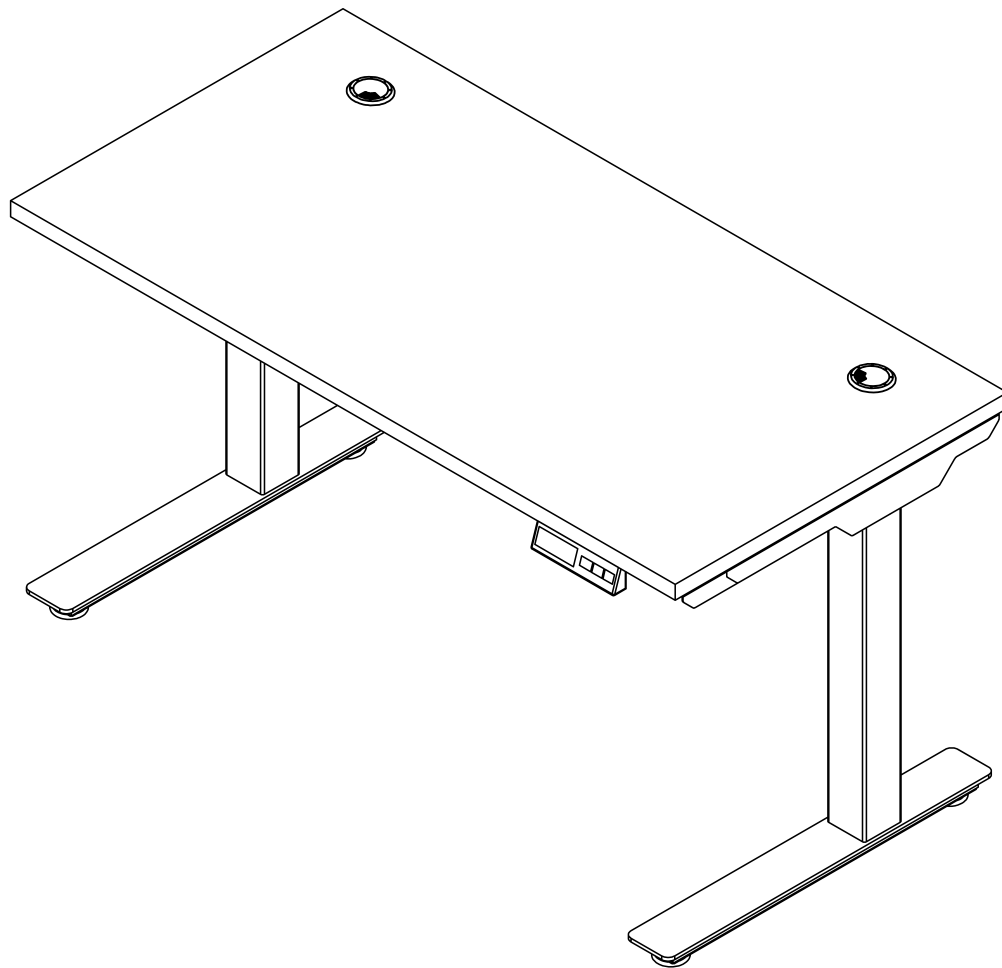

# BOOST

## HEIGHT-ADJUSTABLE WORKSTATION

Includes Add-Ons: **A1 | A2 | A3 | A4**

---

General Installation Guide



**EDITION CODE**

**BHA** :: Workstation.....1

**ADD-ONS**

**A1** :: Casters .....9

**A2** :: Modesty Panel..... 13

**A3** :: Slim Pedestal.....17

**A4** :: Cable Tray ..... 21

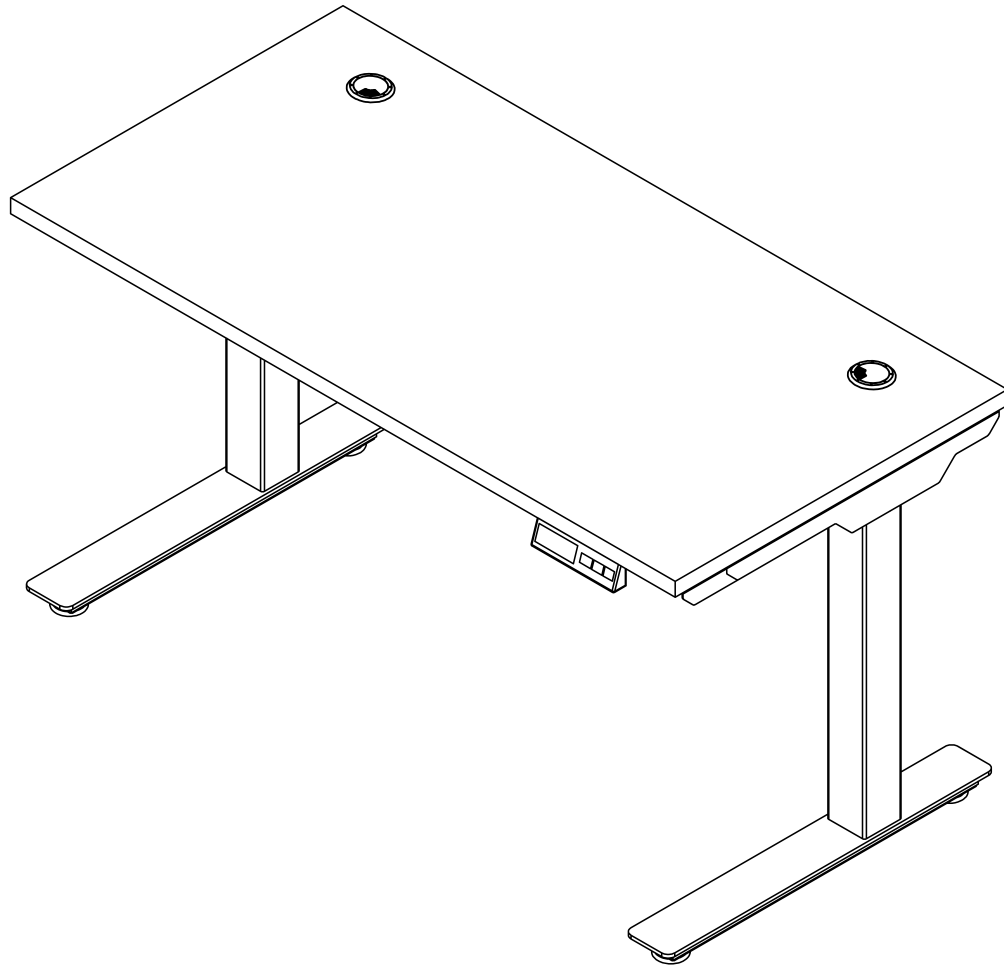

## WORKSTATION

















### OVERVIEW

---

BOOST Height-Adjustable Workstation

**!** All parts listed are for a single workstation; additional parts will be needed for additional workstations.

**PARTS LIST**

CODE	QTY	DESCRIPTION	
#####	1	Surface	
BHA3GSA or BHA2GSA	1	Center-Adjustable Beam	
	1	Feet (Set of 2)	
	2	23" Arm Bracket	
	2	Leg with Motor	
	1	Handset	
	1	Short & Long Extension Cord	
	1	Power Cable	
	8	Screw (A)	
	24	Screw (B)	
	3	Screw (C)	
	8	Screw (D)	
BHANBEAM*	1	BOOST Replacement Beam	
BHA19*	2	19" Arm Bracket	
TLEG. ADAPTGSA*	1	T-Leg Adapter (Set of 2)	
BASB72*	1	42" Support Bar	

\*If applicable.

## 1 | DETERMINE SURFACE SIZE FOR INSTALLATION

Use the chart below to identify which arm brackets will be used with surface size, and if surface will need replacement beam (BHANBEAM).

Note: Reference STEP 4 after completing STEP 2 and 3.

Surface Depth	Surface Width	Including Surface Dividers?	Arm Bracket Type	BHANBEAM	Reference Step 4
24"	36"-47"	No	Default	Yes	A
24"	36"-47"	Yes	BHA19	Yes	B
24"	48"	No	Default	No	C
24"	48"	Yes	BHA19	No	D
24"	54"-72"	No	Default	No	E
24"	54"-72"	Yes	Default	No	F
30"	36"-47"	Yes/No	Default	Yes	G
30"	54"-72"	Yes/No	Default	No	

## 2 | ASSEMBLE WORKSTATION FRAME

Attach legs with motor and arm brackets to the center beam using screws (A).

Note: Replace the default arm brackets if workstation requires BHA19 or T-brackets. Surface width 36"-47" will need to replace the beam, without the control box, with BOOST replacement beam (BHANABEAM).

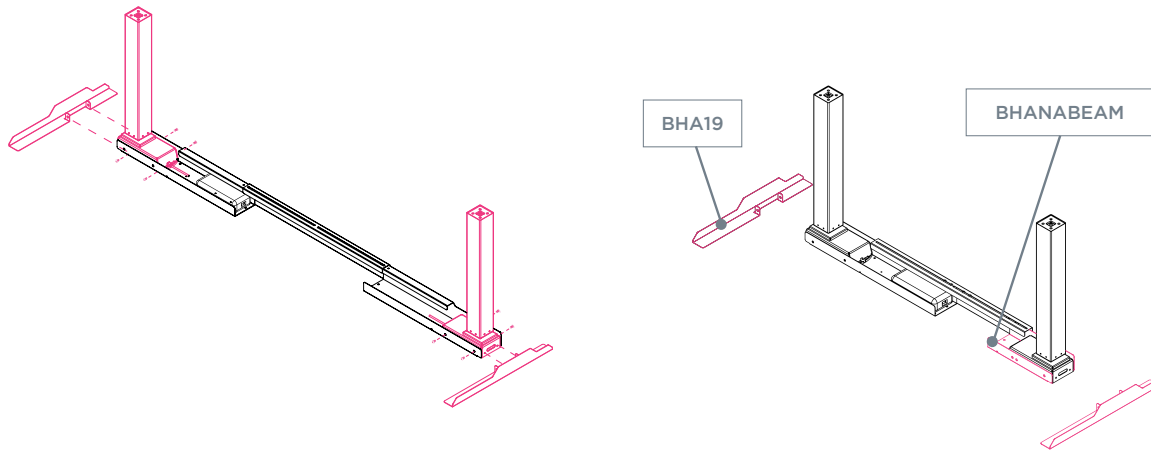

## 3 | PLACE FRAME ON THE SURFACE

Loosen existing locking screws on adjustable beam to extend beam to fit table size. Run cord through cutout from the adjustable beam and secure the handset to control box. Attach the short extension cord to the motor closest to control box and attach the longer extension cord on the opposite end.

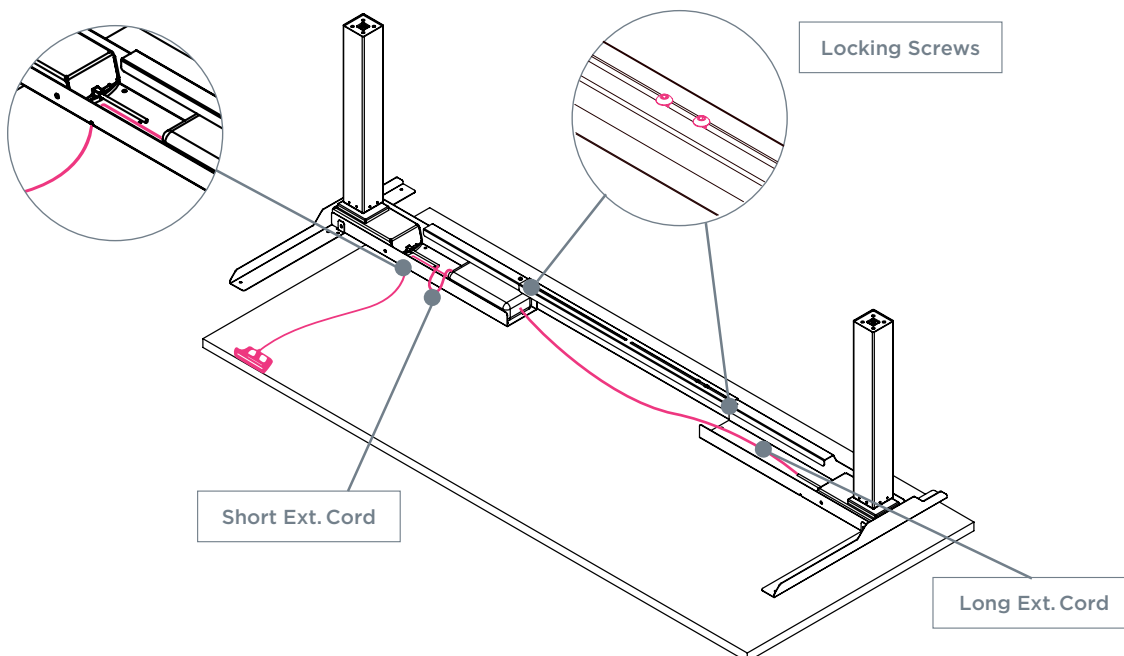

## 4 | ADJUST FRAME ON SURFACE

Note: Based on STEP 1 surface size chart, reference one of the following workstation diagrams to secure frame.

### (A) 24"D x 36"-47"W Surfaces without Side Dividers

Extend the frame equal to the surface width. Center arm brackets in reference to surface depth. Secure frame to surface using wood screws (B) and secure handset using wood screws (C).

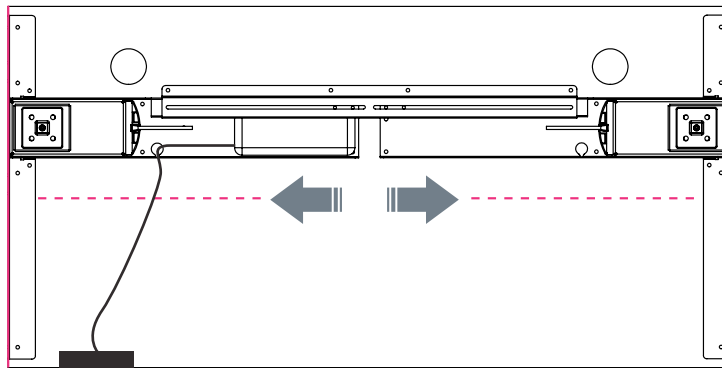

### (B) 24"D x 36"-47"W Surfaces with Side Dividers

If using side dividers, frame will include arm brackets **BHA19**. Extend the frame equal to the surface width. Center arm brackets in reference to surface depth. Secure frame to surface using wood screws (B) and secure handset using wood screws (C).

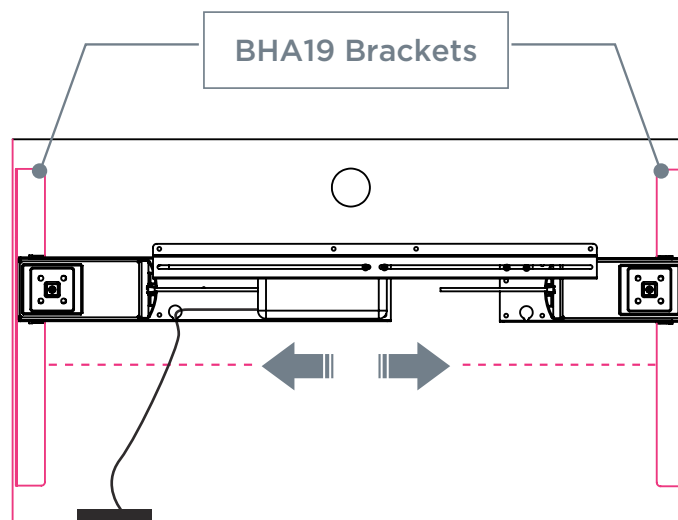

**(C) 24"D x 48"W and Smaller Surfaces without Side Dividers**

Extend the frame equal to the surface width. Center arm brackets in reference to surface depth. Secure frame to surface using wood screws (B) and secure handset using wood screws (C).

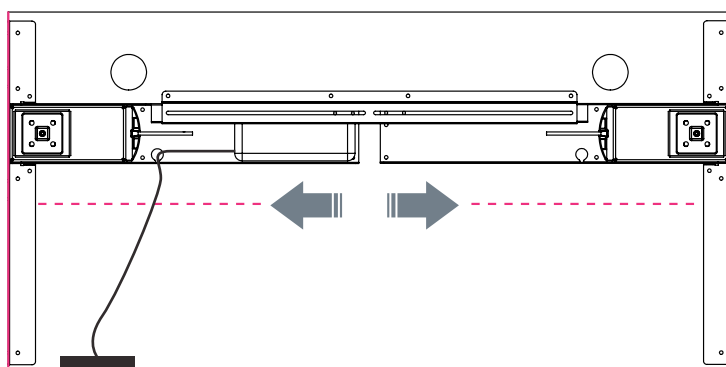

**(D) 24"D x 48"W and Smaller Surfaces with Side Dividers**

If using side dividers, frame will include arm brackets **BHA19**. Extend the frame equal to the surface width. Center arm brackets in reference to surface depth. Secure frame to surface using wood screws (B) and secure handset using wood screws (C).

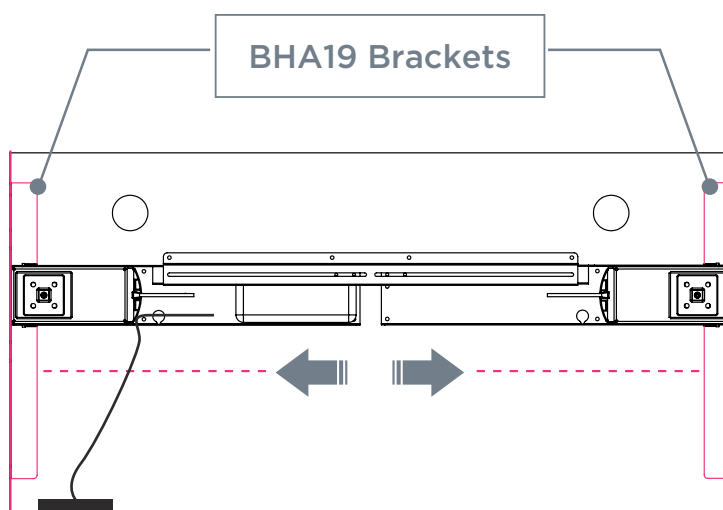

**(E) 24"D x 54"-72"W Surfaces without Dividers**

Extend the frame equal to the surface width. Center arm brackets in reference to surface depth. Secure frame to surface using wood screws (B) and secure handset using wood screws (C).

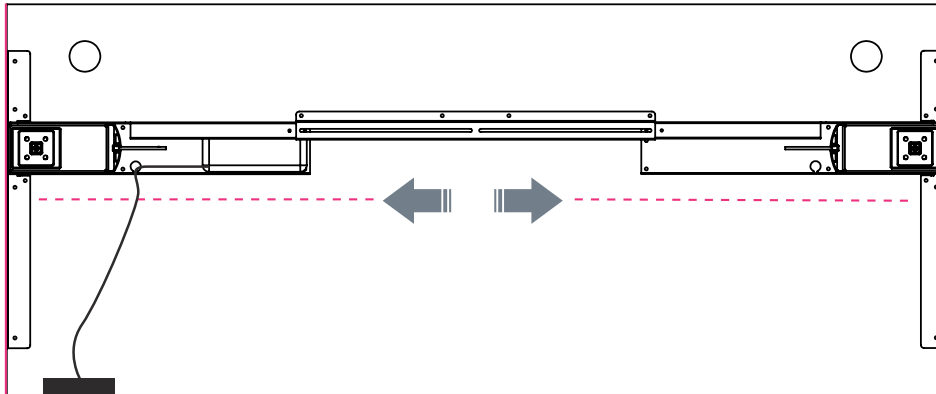

**(F) 24"D x 54"-72"W Surfaces with Side Dividers**

If using side dividers, inset the frame 2" from each end. Center arm brackets to surface depth. Secure frame to surface using wood screws (B) and secure handset using wood screws (C).

**Note:** If using side dividers AND a facing divider with BSBHL, replace the arm brackets with BHA19.

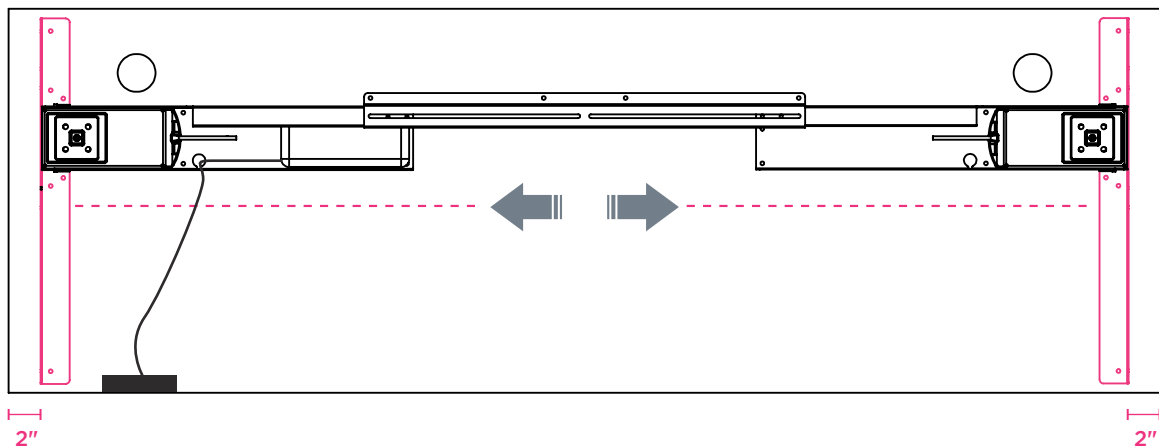

### (G) 30" Deep Surfaces

Extend the frame equal to the surface width. Center arm brackets to surface depth. Secure frame to surface using wood screws (B) and secure handset using wood screws (C).

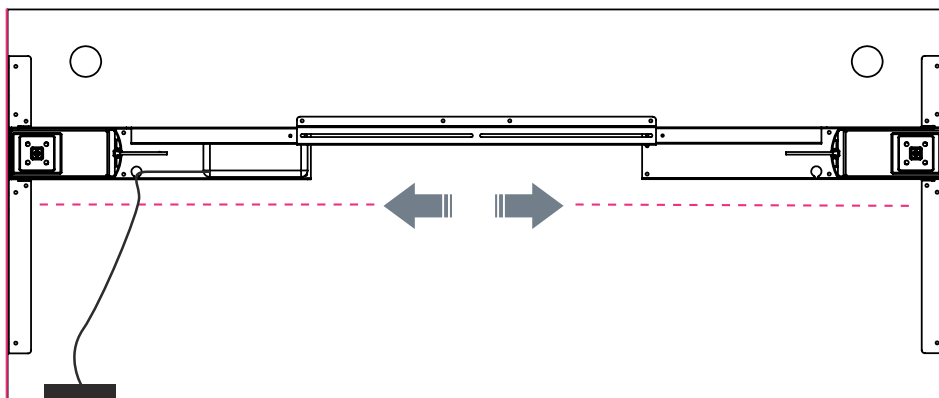

## 5 | SECURE POWER CORD & INSTALL FEET

Secure power cord to the control box. Secure locking screws on the adjustable beam and install the feet using screws (D) for each leg. If workstation is complete, flip over. Reference handset guide for initialization and operation functions.

**Note:** Use T-feet if using T-arm brackets.

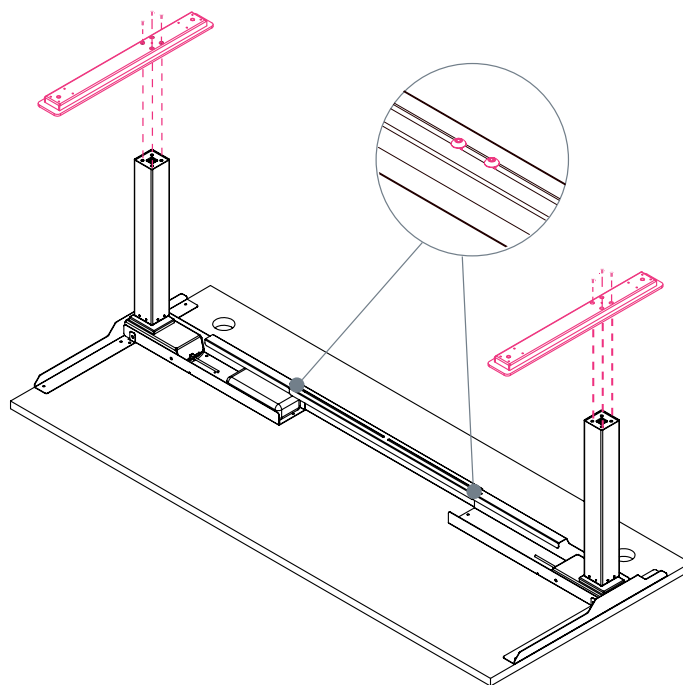

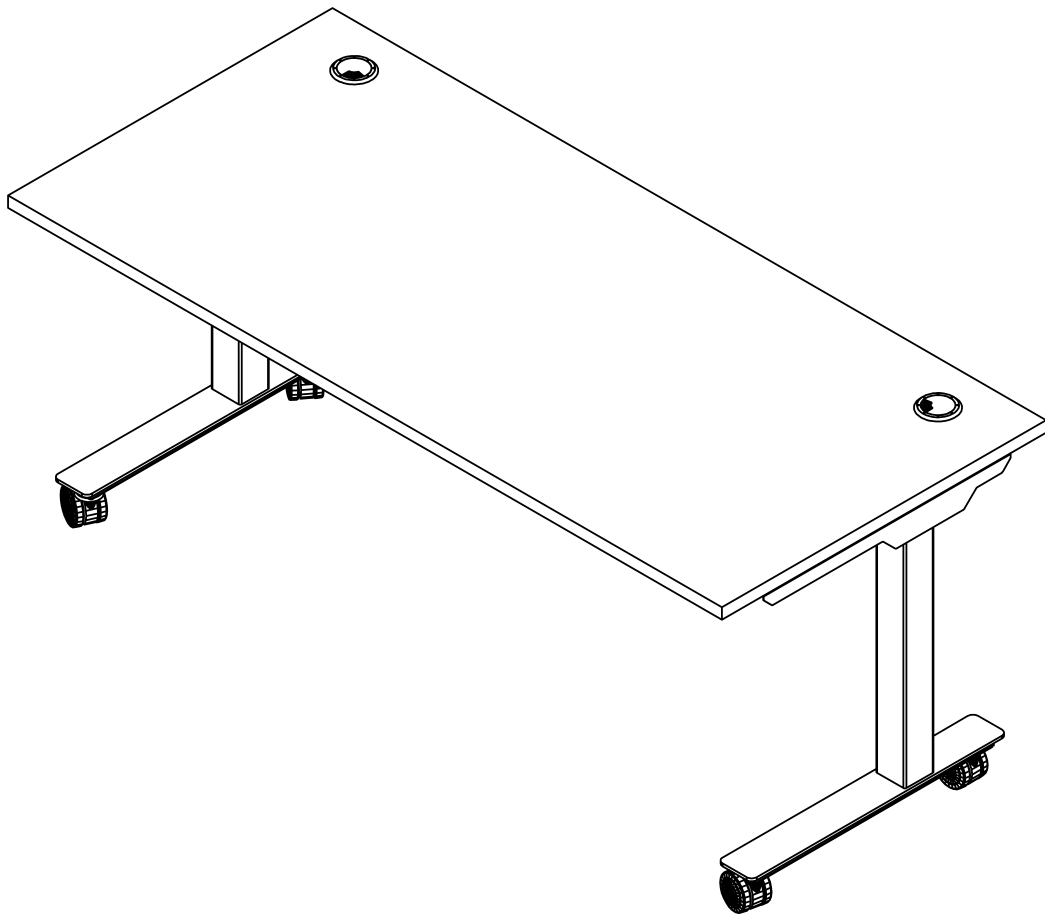

## A1: CASTERS

### OVERVIEW

---

BOOST Height-Adjustable Workstation

**!** All parts listed are for a set of 4 casters;  
additional parts will be needed for additional casters.

**PARTS LIST**

CODE	QTY	DESCRIPTION	
BHACAST	1	Caster Kit (Set of 4)	
	16	Screws	

## 1 | REMOVE GLIDES FROM FEET

Unscrew all four glides from feet and disregard.

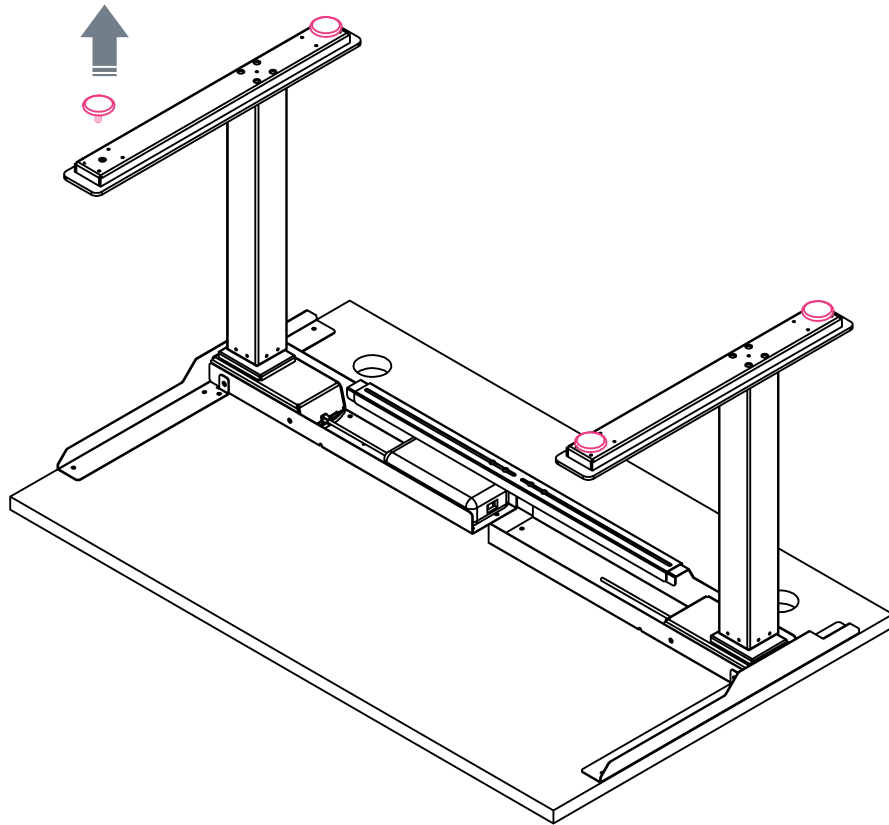

## 2 | ATTACH CASTERS TO FEET

The workstation's feet have pre-drilled holes for the caster plate. Attach casters using self-tapping metal screws.

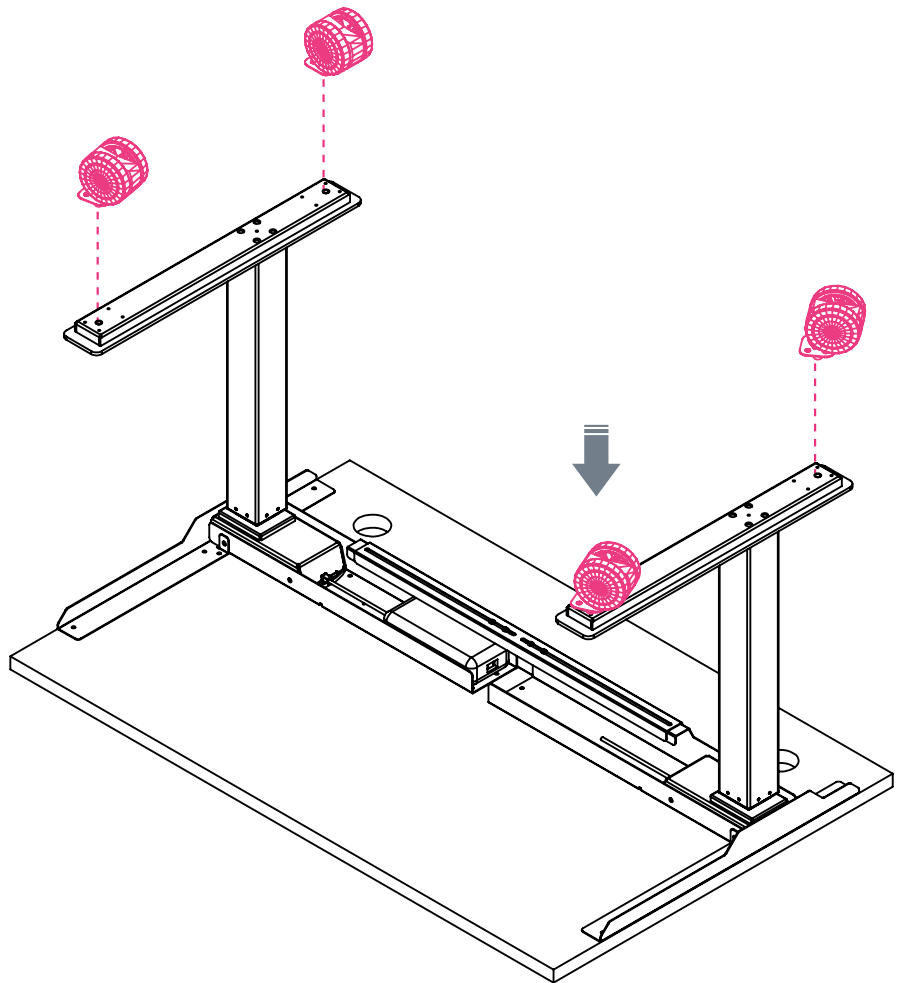

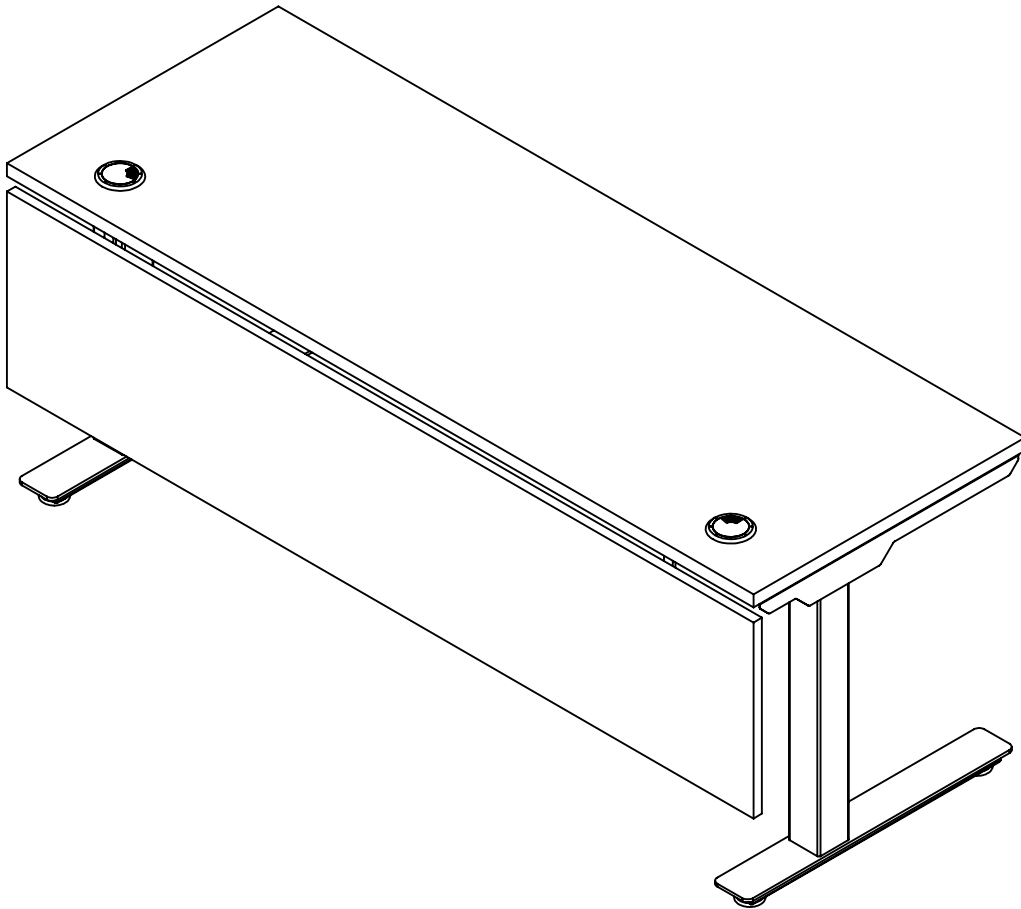

## A1: MODESTY PANEL





### OVERVIEW

---

BOOST Height-Adjustable Workstation

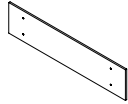
**!** All parts listed are for a single modesty panel; additional parts will be needed for additional modesty panels.

**PARTS LIST**

CODE	QTY	DESCRIPTION	
GLMP##	1	Laminate Modesty Panel*	
	4	Machine Screws	
BMPBFB	2	L-Brackets	
	4	Wood Screws	

\*For Steel Modesty Panel: components may vary, but process is similar.

## 1 | SECURE BRACKETS TO MODESTY PANEL

Connect the BMPBFB bracket to the modesty panel using screws.  
Secure tightly.

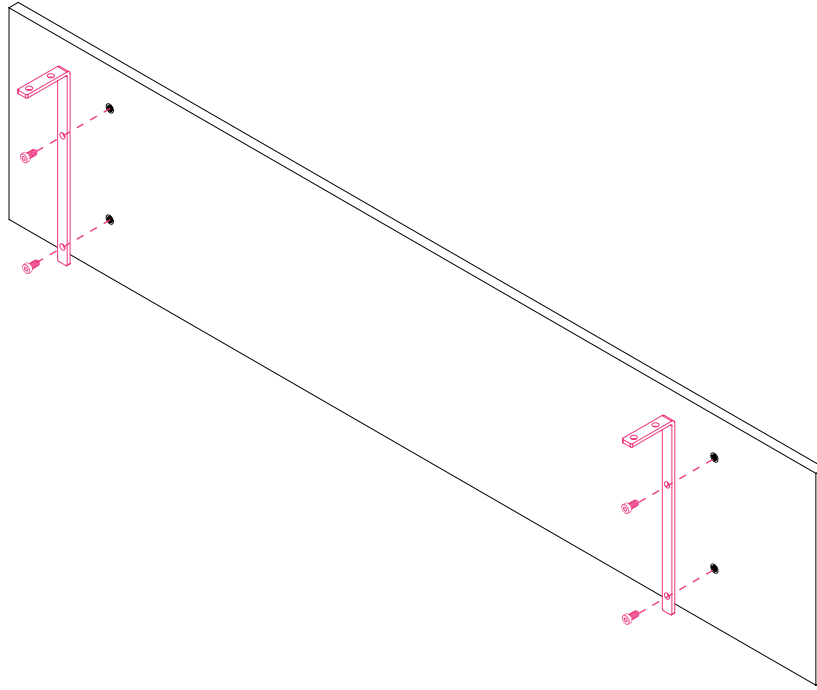

## 2 | ATTACH MODESTY PANEL TO SURFACE

Attach modesty panel to surface using wood screws provided with brackets. Panel will be center aligned and flushed with back of surface.

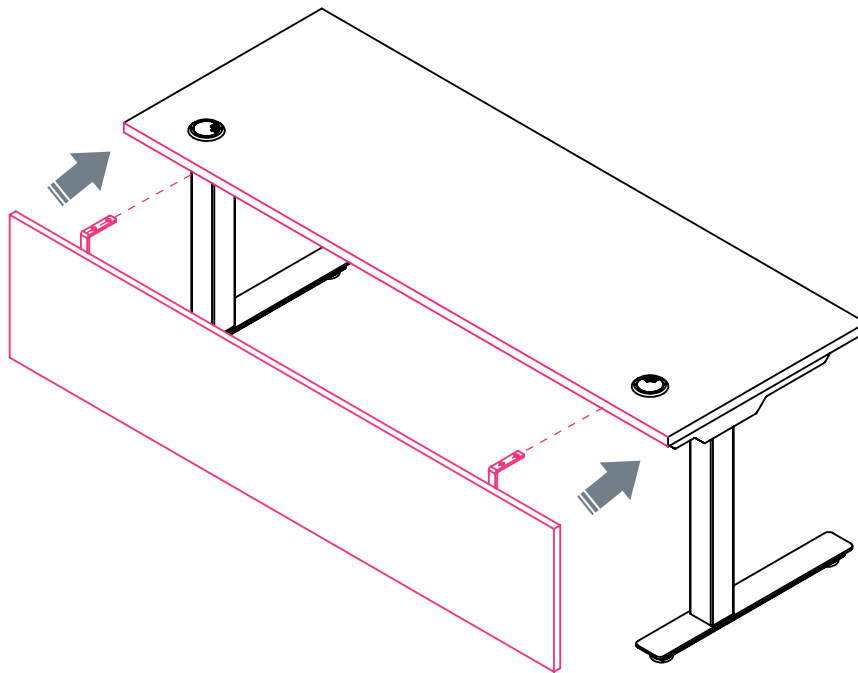

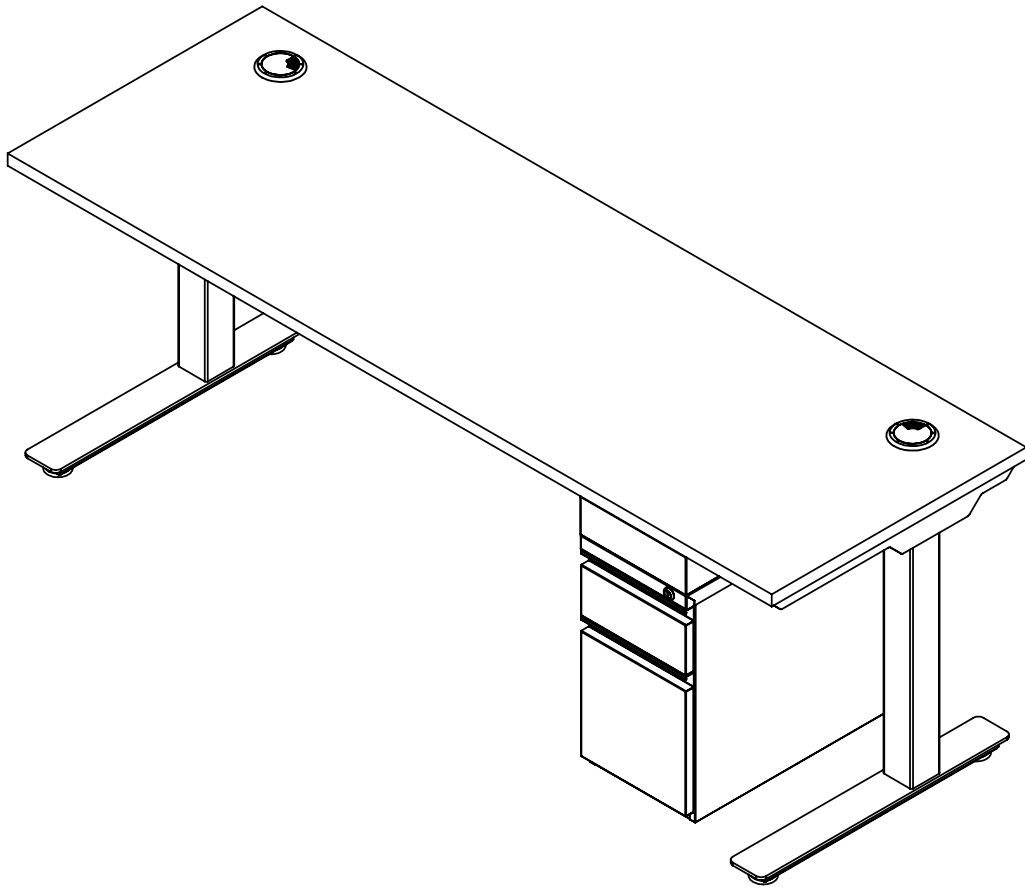

## A2: SLIM PEDESTAL

### OVERVIEW

---

BOOST Height-Adjustable Workstation

**!** All parts listed are for a single slim pedestal; additional parts will be needed for additional slim pedestals.

## PARTS LIST

CODE	QTY	DESCRIPTION	
BFSLM.SM	1	Large Mounting Bracket	
	1	Small Mounting Bracket	
BFSLM	1	Slim Pedestal	
BFSLM.HW	8	Machine Screw	
	10	Wood Screw	

## 1 | SECURE BRACKETS TO SLIM PEDESTAL

Align large mounting bracket to front of pedestal and align small mounting bracket to back. Secure both brackets using provided screws.

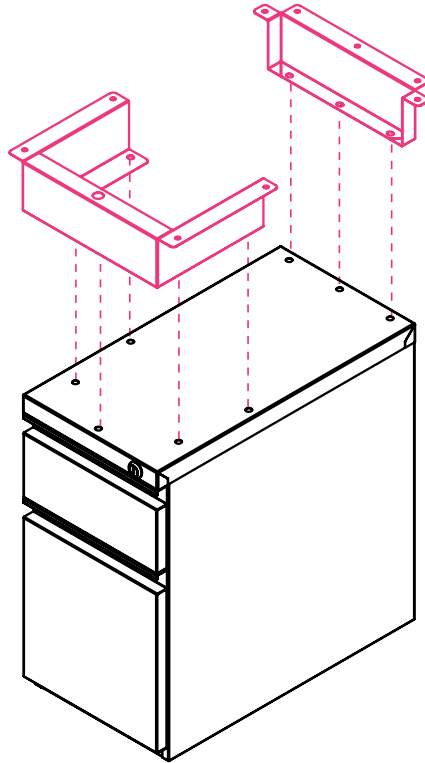

## 2 | ATTACH SLIM PEDESTAL TO SURFACE

Secure pedestal to surface using wood screws. The pedestal brackets will connect on either side of the center beam.

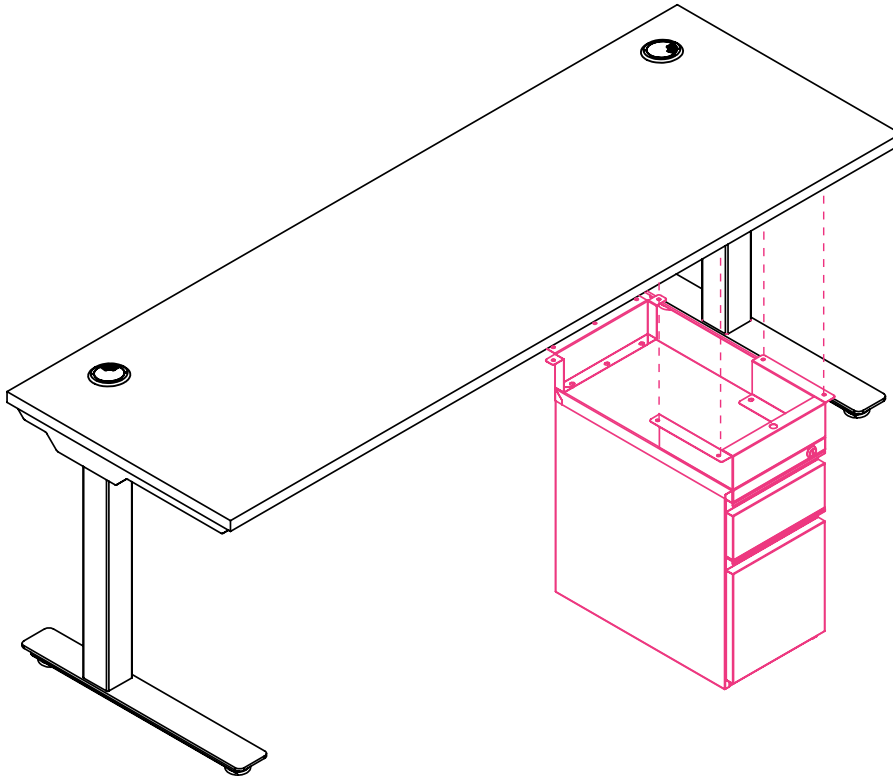

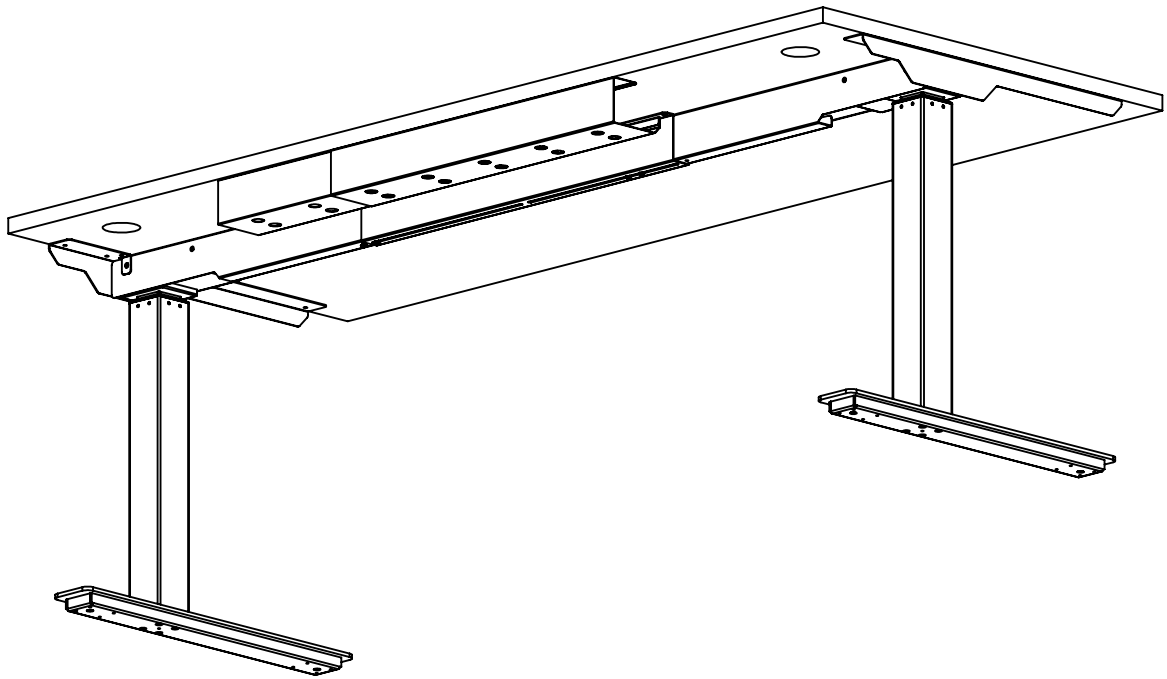

## A3: CABLE TRAY



### OVERVIEW

---

BOOST Height-Adjustable Workstation

**!** All parts listed are for a single cable tray; additional parts will be needed for additional cable trays.

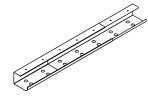
**PARTS LIST**

CODE	QTY	DESCRIPTION	
BHCT	1	Surface-Mount Cable Management Tray	
	10	Wood Screws	

## 1 | EXTEND CABLE TRAY TO DESIRED LENGTH

Extension range: 25"-45".

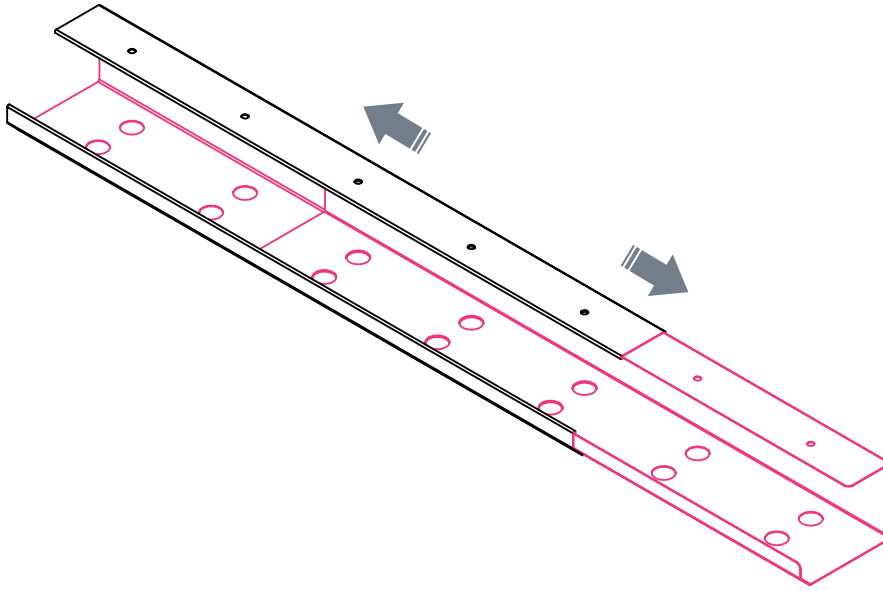

## 2 | ATTACH CABLE TRAY TO SURFACE

Attach cable tray using wood screws.

